

EN

ORIGINAL INSTRUCTIONS
DIGITAL TRUE RMS MULTIMETER

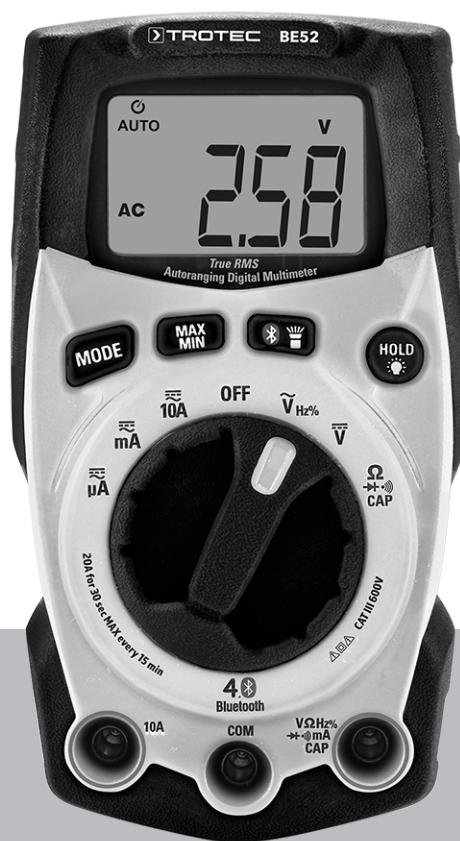

Table of contents

Notes regarding the instructions 2

Safety 2

Information about the device 4

Transport and storage 7

Operation 8

MultiMeasure Mobile app 13

Maintenance and repair 17

Errors and faults 17

Disposal 18

Declaration of conformity 18

Notes regarding the instructions

Symbols



Warning of electrical voltage

This symbol indicates dangers to the life and health of persons due to electrical voltage.



Warning

This signal word indicates a hazard with an average risk level which, if not avoided, can result in serious injury or death.



Caution

This signal word indicates a hazard with a low risk level which, if not avoided, can result in minor or moderate injury.

Note

This signal word indicates important information (e.g. material damage), but does not indicate hazards.



Info

Information marked with this symbol helps you to carry out your tasks quickly and safely.



Follow the manual

Information marked with this symbol indicates that the instructions must be observed.

You can download the current version of the instructions and the EU declaration of conformity via the following link:



BE52



<https://hub.trotec.com/?id=46448>

Safety

Read this manual carefully before starting or using the device. Always store the manual in the immediate vicinity of the device or its site of use.



Warning

Read all safety warnings and all instructions.

Failure to follow the warnings and instructions may result in electric shock, fire and/or serious injury.

Save all warnings and instructions for future reference.

- The device is supplied with a warning sign. Prior to initial start-up, make sure to paste the corresponding warning sign in your local language over the one present at the rear of the device as described in chapter Operation.

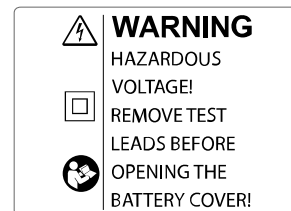

- Do not use the device in potentially explosive rooms or areas and do not install it there.
- Do not use the device in aggressive atmosphere.
- Protect the device from permanent direct sunlight.
- Do not remove any safety signs, stickers or labels from the device. Keep all safety signs, stickers and labels in legible condition.
- Do not open the device.
- Never charge batteries that cannot be recharged.
- Different types of batteries and new and used batteries must not be used together.
- Insert the batteries into the battery compartment according to the correct polarity.
- Remove discharged batteries from the device. Batteries contain materials hazardous to the environment. Dispose of the batteries according to the national regulations.

- Remove the batteries from the device if you will not be using the device for a longer period of time.
- Never short-circuit the supply terminal in the battery compartment!
- Do not swallow batteries! If a battery is swallowed, it can cause severe internal burns within 2 hours! These burns can lead to death!
- If you think batteries might have been swallowed or otherwise entered the body, seek medical attention immediately!
- Keep new and used batteries and an open battery compartment away from children.
- Disconnect the measuring cables from the device before replacing the batteries.
- Do not exceed the measuring range of a function specified in the technical data.
- Always disconnect the measuring tips from the circuit before changing the measuring mode.
- Proceed with the utmost care when measuring voltages above 25 VAC rms or 35 VDC. There is a risk of an electric shock at these voltage levels.
- Ensure that the measuring area has zero potential and the capacitors are discharged before you carry out diode, resistance or continuity tests. Disconnect the measuring lines from the measuring area before switching over the device to diode, resistance or continuity tests if you have previously carried out measurements on live components

Intended use

Only use the device for measurements within the measuring ranges and overvoltage categories specified in the technical data.

Intended use comprises:

- measurements of AC and DC voltages
- measurements of direct and alternating currents
- capacitance measurements
- frequency / duty cycle measurements
- resistance measurements
- testing diodes
- acoustic continuity tests
- Temperature measurements with external type K sensor

To use the device for its intended use, only use accessories and spare parts which have been approved by Trotec.

Foreseeable misuse

Do not use the device in potentially explosive atmospheres, when wet or very humid.

Unauthorized modifications of the device are forbidden.

Personnel qualifications

People who use this device must:



- master the 5 safety rules of electrical engineering
 - 1. De-energise
 - 2. Secure against restart
 - 3. Verify de-energised state (bipolar)
 - 4. Earth and short-circuit
 - 5. Cover neighbouring live parts
- take measures to protect themselves from direct contact with live parts.
- have read and understood the instructions, especially the Safety chapter.

Safety signs and labels on the device

Note

Do not remove any safety signs, stickers or labels from the device. Keep all safety signs, stickers and labels in legible condition.

The following safety signs and labels are attached to the device:

Safety symbol	Meaning
	This sign warns you of hazards when using electric power. Exercise caution and observe the safety instructions.
	The device is provided with double insulation against electric shock.
	This sign indicates that the operating manual must be observed.

Residual risks



Warning of electrical voltage

Electric shock due to insufficient insulation! Check the device and the measuring cables for damages and proper function before each use. If you detect damages, do not use the device any longer.

Do not use the device when either the device or your hands are damp or wet!

Do not use the device when the battery compartment or the housing is open.



Warning of electrical voltage

Electric shock due to contact with live parts! When using the measuring tips, make sure not to reach behind the protection against contact.

**Warning of electrical voltage**

There is a risk of a short-circuit due to liquids penetrating the housing!
Do not immerse the device and the accessories in water. Make sure that no water or other liquids can enter the housing.

**Warning of electrical voltage**

Work on the electrical components must only be carried out by an authorised specialist company!

**Warning**

Risk of suffocation!
Do not leave the packaging lying around. Children may use it as a dangerous toy.

**Warning**

The device is not a toy and does not belong in the hands of children.

**Warning**

Dangers can occur at the device when it is used by untrained people in an unprofessional or improper way! Observe the personnel qualifications!

**Caution**

When handling the device there is a risk of injury due to the exposed measuring tips.
Always put on the protective cap when not in use.

**Caution**

Keep a sufficient distance from heat sources.

Note

To avoid damages to the device, make sure that the correct measuring range is selected before carrying out a measurement.

If you are unsure, select the largest measuring range. Remove the measuring cables from the measuring point before changing the measuring range.

Note

To prevent damages to the device, do not expose it to extreme temperatures, extreme humidity or moisture.

Note

Do not use abrasive cleaners or solvents to clean the device.

Note

Before commissioning, check the function of the device at a known voltage source, e.g. on a known and safe 230 V voltage source or on a known and safe 9 V battery. Select the correct measuring range!

Information about the device**Device description**

The multimeter is a battery-powered, mobile hand-held measuring device with an extensive range of measurement possibilities. The true RMS measuring function allows for the precise measurement of sinusoidal and non-sinusoidal signals generated due to faults, e.g. by frequency inverters or switching power supplies of computers.

The device is equipped with the following functional properties and equipment features:

- Automatic / manual range selection
- LCD display
- Can also be operated while wearing gloves
- Fold-out stand and holding fixture for measuring tips
- AC and DC voltage measurement
- Measurement of direct and alternating currents
- Resistance measurement
- Capacitance measurement
- Frequency / duty cycle measurement
- Diode testing function
- Acoustic continuity testing
- Hold function
- Calling the maximum and minimum value

The integrated Bluetooth function makes it possible to connect the device to a terminal device via the Trotec MultiMeasure Mobile app.

The measurement results can be displayed and saved on the terminal device either numerically or in form of a chart. Then, the measurement data can be sent in PDF or Excel format.

The app also includes a report generation function, an organiser function, one for customer management and further analysis options. Moreover, it is possible to share measurements and project data with colleagues in another subsidiary. If MultiMeasure Studio Professional is installed on a PC, you can even use report templates and ready-made text blocks for various fields of application to turn the data into professional reports.

Overvoltage protection and measurement category

The power grid is permanently subjected to short-time voltage peaks, the so-called voltage surge, which can be very low, for instance when a light switch is actuated, but also very high when a network operator switches over power lines. The height of the surge voltage depends on the position within a low-voltage network in which a device/machine is operated. The closer this position is to the supply line, the higher is the surge voltage to be expected. This means that an electricity meter of a house must be able to absorb a higher surge voltage than a Wlan router.

For the purpose of simplification, the power grid is divided into four overvoltage categories. A rated surge voltage is assigned to overvoltage categories in each case, indicating the voltage peaks for which a device has to be designed:

Overvoltage category	Rated surge voltage	Examples
CAT I	1500 V	Devices with power adapter: e.g.: laptops, monitors, telephones
CAT II	2500 V	Devices with cold-device plugs: e.g.: household appliances, printers, laboratory equipment, telephone system
CAT III	4000 V	Devices without a plug: e.g.: sub-distributions, cables, sockets, CNC machines, construction cranes, energy storage systems
CAT IV	6000 V	Devices at the feed point: e.g.: electricity meters, primary overcurrent protection devices, main switches

In line with the overvoltage categories there are measurement categories defining the permissible scope of application of measurement and testing devices for electrical equipment and systems in low-voltage networks.

The design of a measurement device determines in which environments and for which voltages it can be safely used. What is important in this connection for example is the touchability of live parts, anti-kink protection guards on the measuring lines or the insulation. Depending on the design details, the measurement device can carry out safe measurements up to a specific voltage in one or several overvoltage categories. The measurement category is specified on the measurement device as well as in the operating manual.

The measurement category is indicated including the maximum voltage height, which can either be 300, 600 or 1000 Volt. The designation CAT III/1000 V for example means that the measurement device may be used in low-voltage indoor installation for voltages up to 1000 volts.

Often several values are indicated on the device, for instance CAT III/ 1000 V and CAT IV/600 V. In these cases, different maximum voltages apply to the stated scopes of application. If no measurement category is specified, the measurement device is only considered as safe in measurement category CAT I.

This measurement device is suited for category CAT III (600 V).

Device depiction

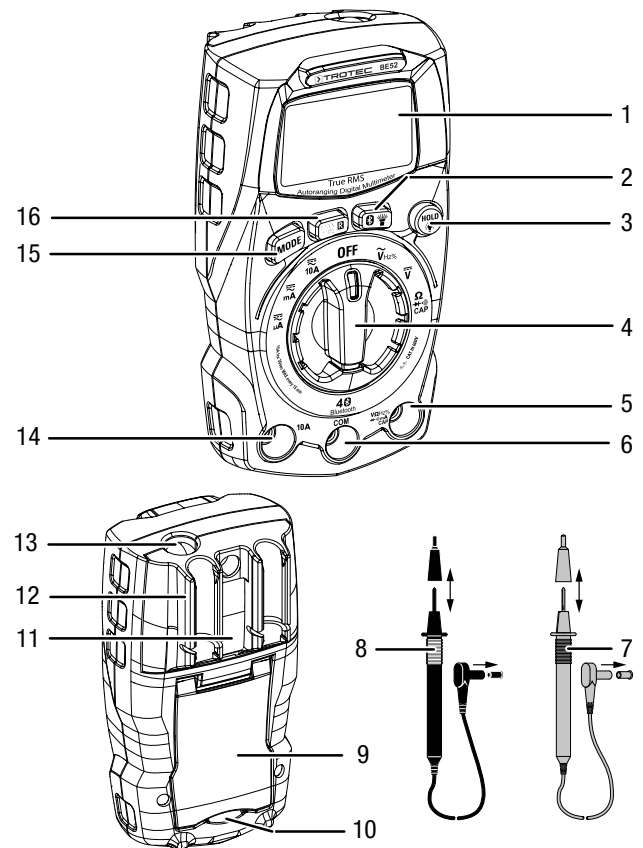

No.	Designation
1	LC display
2	⚡ button
3	HOLD/💡 button
4	Rotary switch
5	Measuring socket $V\Omega$
6	Measuring socket COM
7	Red measuring tip
8	Black measuring tip
9	Fold-out stand
10	Fuse compartment
11	Battery compartment
12	Holding fixture for measuring tips
13	Work light
14	Measuring socket $10 A$
15	MODE button
16	MAX/MIN/R button

Rotary switch

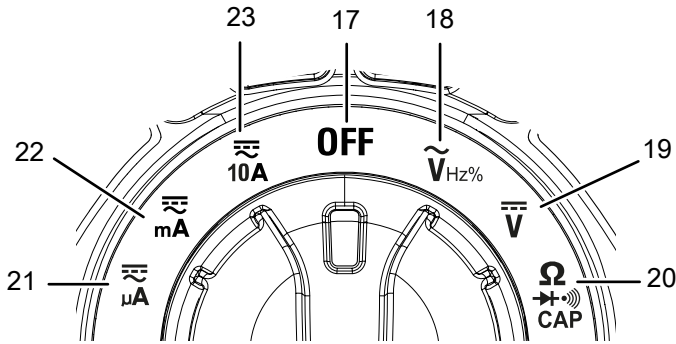

No.	position	Description
17	OFF	Device is switched off.
18	$\tilde{V}_{Hz\%}$	AC voltage: 0.001 mV to 1000 V Frequency measurement: 0.01 Hz to 9999 Hz Duty cycle: 1 % to 99 %
19	\bar{V}	DC voltage: 0.1 mV to 1000 V
20	Ω / \rightarrow / \rightarrow / CAP	Resistance measurement: 0.1 Ω to 40 M Ω Diode test / continuity measurement Capacitance measurement: 0.01 nF to 4000 μ F
21	$I_{\mu A}$	Direct and alternating current: up to 6000 μ A
22	I_{mA}	Direct and alternating current: up to 400 mA
23	I_{10A}	Direct and alternating current: up to 10 A

Technical data

General characteristics

Parameter	Value
Insulation	double
Diode test	Test current of 0.3 mA, test voltage < 3.3 V DC typically
Continuity test	An acoustic signal is emitted if the resistance amount to less than 50 Ω . Test current: < 0.5 mA
LC display	3 3/4 digits, 4000 count LCD, with background illumination
Exceedance of the measuring range (outside limits)	OL will be displayed.
Polarity	Automatic (no indication for positive); minus (-) sign for negative
Measuring speed	2 x per second, nominal
Bluetooth frequency range	2.4 GHz
Bluetooth max. transmission power	0 dBm
Battery indication	The battery icon will be displayed when the battery voltage drops below the operating voltage threshold.
Battery	2 x 1.5 V, type AAA
Fuses	μ A/mA range: 500 mA / 600 V 10 A range: 10 A / 600 V (measurement up to 10 A for 30 seconds possible. Afterwards a break of 15 minutes must be observed.)
Operating temperature	5°C to 40°C (41°F to 104°F)
Storage temperature	-20°C to 60°C (-4°F to 140°F)
Relative humidity for operation	< 80 % to 31 °C (87 °F), linearly decreasing to 50 % at 40 °C (104 °F)
Relative humidity for storage	< 80 %
Operating height above sea level	Max. 2000 m (7000 ft)
Type of protection	IP40
Weight	approx. 140 g
Dimensions (length x width x height)	121 x 67 x 45 mm
Automatic switch-off	after approx. 15 minutes of non-use
Safety	This measuring device is designed for indoor use and complies with overvoltage category CAT III (600 V).

Measuring ranges

Function	Measuring range	Resolution	Accuracy
DC voltage (V DC)	400.0 mV	0.1 mV	± (1 % + 8 digits)
	4.000 V	0.001 V	± (1 % + 3 digits)
	40.00 V	0.01 V	
	400.0 V	0.1 V	
	600 V	1 V	± (1.2 % + 3 digits)
AC voltage (V AC) (50 / 60 Hz)	4.000 V	0.001 V	± (1.0 % + 5 digits)
	40.00 V	0.01 V	
	400.0 V	0.1 V	
	600 V	1 V	± (1.2 % + 5 digits)
Direct current (A DC)	400.0 µA	0.1 µA	± (1.0 % + 3 digits)
	4000 µA	1 µA	± (1.5 % + 3 digits)
	40.00 mA	0.01 mA	
	400.0 mA	0.1 mA	
	10 A	0.01 A	± (2.5 % + 5 digits)
Alternating current (A AC) (50 / 60 Hz)	400.0 µA	0.1 µA	± (2.0 % + 5 digits)
	4000 µA	1 µA	± (2.5 % + 5 digits)
	40.00 mA	0.01 mA	
	400.0 mA	0.1 mA	
	10 A	0.01 mA	± (3.0 % + 7 digits)
Capacitance (nF)	40 nF	0.01 nF	± (5.0 % + 35 digits)
	400 nF	0.1 nF	± (3.0 % + 5 digits)
	4.000 µF	0.001 µF	
	40.00 µF	0.01 µF	± (4.0 % + 5 digits)
	400.0 µF	0.1 µF	
	4000 µF	1 µF	
Resistance (Ω)	400.0 Ω	0.1 Ω	± (1.0 % + 4 digits)
	4.000 kΩ	0.001 kΩ	± (1.5 % + 5 digits)
	40.00 kΩ	0.01 kΩ	
	400.0 kΩ	0.1 kΩ	
	4.000 MΩ	0.001 MΩ	± (3.5 % + 5 digits)
	40.00 MΩ	0.01 MΩ	

Function	Measuring range	Resolution	Accuracy
Frequency	9.99 Hz	0.01 Hz	± (1.0 % + 5 digits)
	99.99 Hz		
	999.9 Hz	0.1 Hz	
	9999 Hz	1 Hz	
Duty factor	1-99 %	1 %	± (1.2 % + 5 digits)
	Pulse width: 100 µs to 100 ms, frequency: 5 Hz to 100 kHz		

Note:

The accuracy is based on an ambient temperature of 18 °C to 28 °C and a relative humidity of less than 80 %.

The accuracy specification consists of two values:

- % value referring to the reading
- + digits: Deviation in the last digit

Scope of delivery

- 1 x device BE52
- 2 x Measuring tip
- 2 x 1.5 V battery AAA
- 1 x Quick guide

Transport and storage

Note

If you store or transport the device improperly, the device may be damaged.

Note the information regarding transport and storage of the device.

Transport

When transporting the device, ensure dry conditions and protect the device from external influences e.g. by using a suitable bag.

Storage

When the device is not being used, observe the following storage conditions:

- dry and protected from frost and heat
- protected from dust and direct sunlight
- the storage temperature complies with the values specified in the Technical data
- Batteries are removed from the device

Operation



Warning of electrical voltage

Electric shock due to contact with live parts! When using the measuring tips, make sure not to reach behind the protection against contact.

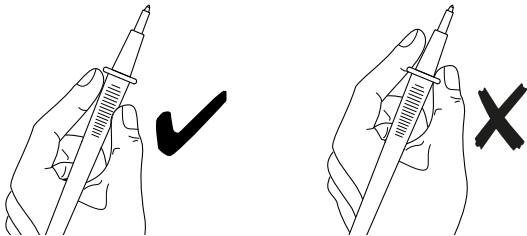

Only remove the protective caps of the measuring tips briefly if this is required for a measurement. Fit the protective caps immediately again after the measurement, in order to prevent injuries caused by negligence.

Inserting the batteries

Insert the batteries before first use.

Note

Disconnect the measuring tips from the device before opening the battery compartment.

Note

Make sure that the surface of the device is dry and the device is switched off.

1. Loosen the screw at the battery compartment (11).
2. Open the battery compartment.
3. Insert the batteries (2 x 1.5 V batteries AAA) into the battery compartment with correct polarity.

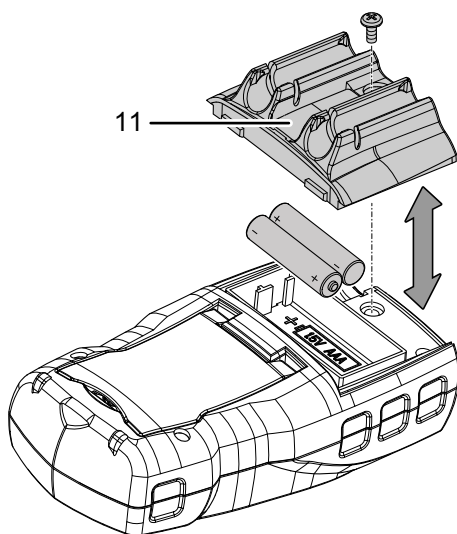

Attaching the warning signs

Prior to initial start-up, make sure that the warning sign at the rear of the device and the warning sign below the stand are in your local language, if not, paste the proper ones over them. Warning signs in your native language are supplied along with the device. Please proceed as follows to attach the warning signs to the rear of the device:

1. Remove the labels in your local language from the supplied film.
2. Stick the labels onto the places that are provided for this purpose on the stand and on the fuse compartment below the stand.

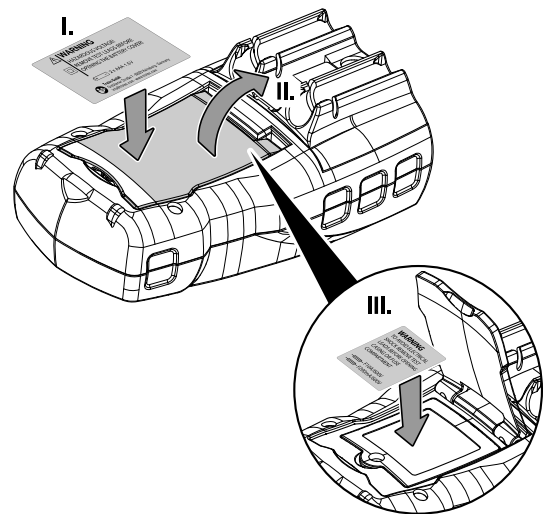

Undefined displays

If measuring inputs are open or touched by hand, this can lead to undefined displays. This is not a malfunction but a reaction of the sensitive measuring input to existing interference voltages.

Normally, when there is no high interference level at the workplace or in case of a short circuit at the measuring input zero is displayed immediately. Or, if the measuring object is connected, the exact measured value is displayed. Fluctuations in the displayed value by some digits are systemic and within the tolerance.

If the resistance measuring range, the continuity testing range or the diode test was selected and the measuring input is open, the *OL* indication (exceedance of the measuring range) will be displayed.

4. Close the battery compartment and retighten the screw.

IMPORTANT INFORMATION ON THE MEASURING PROCESS!



Warning of electrical voltage

Improper handling of the measuring device entails a risk of electric shock!

Before carrying out voltage measurements, observe the following:

- Never apply a voltage exceeding the rated nominal voltage of the measuring device between the connections or between the connections and earth (see imprint on the housing).
- Check the measuring tips for damaged insulation and for continuity. Replace damaged measuring tips.
- Check the insulation of the measuring device sockets.
- Before commissioning, check the function of the device at a known voltage source, e.g. on a known and safe 230 V voltage source or on a known and safe 9 V battery.
- First connect the measuring tip connected to earth and afterwards the live measuring tip. When disconnecting the measuring tips, proceed in reverse order, i.e. disconnect the live measuring tip first.
- Prior to every voltage measurement make sure that the measuring device is not set to the current measuring range.
- If the device indicates an exceedance of the measuring range (*OL*) immediately after being connected to the measuring object, first switch off the circuit at the measuring object, then immediately remove the measuring tips from the measuring object.
- Do not switch any motors in the measuring circuit on or off during a measurement. Voltage peaks caused by a switch-on or switch-off can damage the measuring device.

Operating elements

You can select the following operating elements for the measurement:

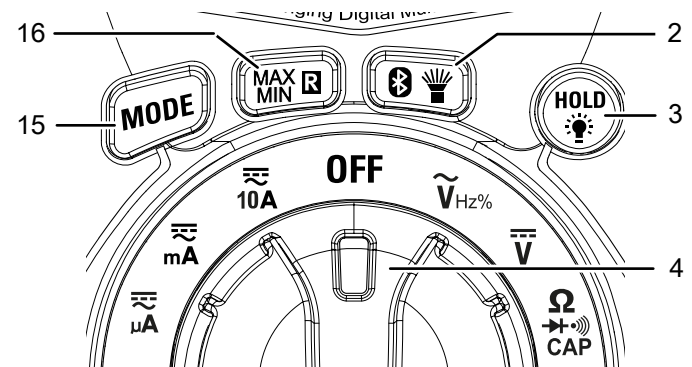

Bluetooth/work light button (2):

- Switching the work light on/off: press briefly
- Enabling/disabling Bluetooth: press for a long time

Hold/display illumination button (3):

- Freezing the measurement value (Hold function): press briefly
- Switching the display illumination on/off: press for a long time

Rotary switch (4):

- Setting the type of measurement

MODE button (15):

- Changing the measuring mode within the type of measurement set

MAX/MIN/R button (16):

- Calling the maximum value: press once
- Calling the minimum value: press twice
- Deactivating the maximum/minimum value indication: Press for 1 second
- Setting the range (decimal places): press for a long time. Then press briefly to adapt the decimal places.

Measuring DC voltage

1. Turn the rotary switch to position \bar{V} (19).
2. Insert the plug of the black measuring tip into the *COM* (6) measuring socket and the plug of the red measuring tip into the *V Ω* (5) measuring socket.
3. Connect both measuring tips to the measuring object with correct polarity (black to minus, red to plus).
 - ⇒ If the input voltage is negative, a minus (-) will appear in front of the measured value on the display.
 - ⇒ The measured value will be indicated on the display.

Example:

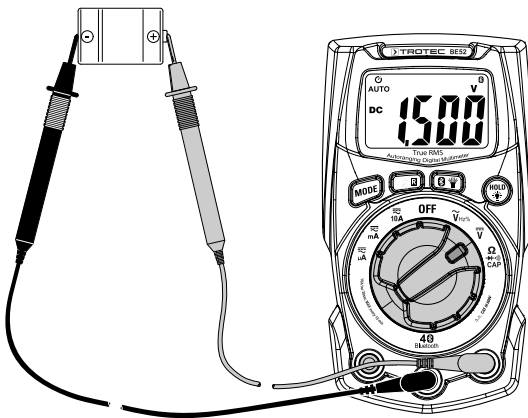

Measuring AC voltage

1. Turn the rotary switch to position $\tilde{V}_{Hz\%}$ (18).
2. Insert the plug of the black measuring tip into the *COM* (6) measuring socket and the plug of the red measuring tip into the *V Ω* (5) measuring socket.
3. Connect both measuring tips to the measuring object.
 - ⇒ If the input voltage is negative, a minus (-) will appear in front of the measured value on the display.
 - ⇒ The measured value will be indicated on the display.

Example:

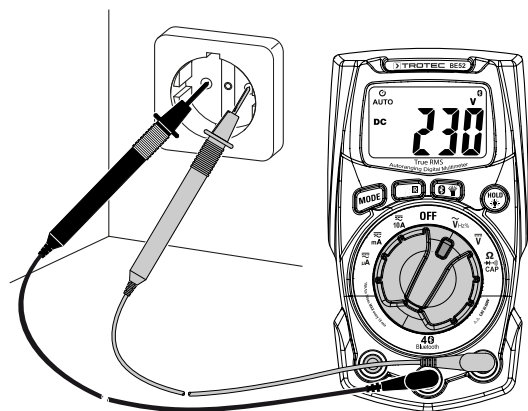

Current measurements

Note

Never connect a voltage source to the multimeter's measuring sockets when a current measuring range is selected. Otherwise the device could be damaged.

Note

Observe that a measurement time of 30 seconds must not be exceeded when carrying out a current measurement of 10 A. After having carried out a measurement up to 10 A, take a break for at least 15 minutes.

- ✓ The electrical circuit is deactivated. The capacitors are discharged.
 - ✓ The voltage in the measuring circuit is not higher than 600 V (CAT III) to ground.
1. Interrupt the circuit to be checked and connect the measuring device in series with the consumer in this circuit.
 2. Depending on the expected measuring current, turn the rotary switch to the following position:
 - up to 6000 μ A: μ A
 - up to 400 mA: mA
 - up to 10 A: 10A.
 3. Use the *MODE* button (15) to select the desired measuring mode (for direct current: *DC* indication) for alternating current: *AC* indication).
 4. Insert the plug of the black measuring tip into the *COM* (6) measuring socket and the plug of the red measuring tip into the *V Ω* (5) (up to 400 mA) or *10 A* (14) measuring socket – depending on the selected range.
 5. Switch off the voltage supply at the measuring object and connect the measuring tips to the measuring object. For direct current, make sure that the polarity of the connection to the measuring object is correct (in series; red to plus, black to minus).
 6. Switch the measuring circuit back on and read the measured value from the display.
 7. If the *OL* indication (exceedance of the measuring range) appears after the manual range selection, immediately switch over to the respectively next higher range. If the *OL* indication appears and the maximum range has been set already or in case of the automatic range selection, immediately switch off the voltage supply at the measuring object and disconnect the measuring device from the measuring object.



Info

If you have selected the 10 A range for safety's sake, but the measuring current amounts to less than 400 mA, switch the measuring circuit back off. Plug the red measuring tip into the *V Ω* measuring socket and select a measuring range in the mA range. Switch the measuring circuit back on.

Example:

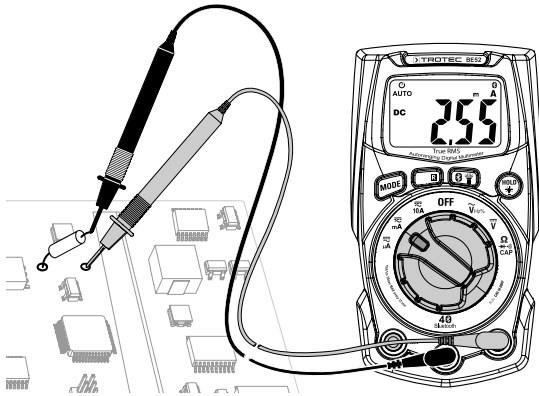

Info

If there is no indication and all connections have been established correctly, the cause of the fault may be a defective internal fuse protecting the current measuring ranges (see chapter Fuse replacement).

Measuring resistance



Warning of electrical voltage

Before carrying out resistance, continuity or diode measurements, switch off the current of the electric circuit and discharge all capacitors.

1. If possible, disconnect other circuit areas from the resistance to be measured, since they may have an impact on the measurement.
2. Set the rotary switch to the $\Omega/\rightarrow+\rightarrow$ /CAP (20) position, then use the *MODE* button (15) to select the resistance measurement (*M Ω* indication).
3. Insert the plug of the red measuring tip into the *V/ Ω* measuring socket (5) and the plug of the black measuring tip into the *COM* measuring socket (6).
4. Connect the measuring tips to the measuring object.
 - ⇒ The measuring device may take some time to display a stable value. This is due to the measuring principle and not a malfunction.
 - ⇒ The measured value will be indicated on the display.

Continuity test



Warning of electrical voltage

Before carrying out resistance, continuity or diode measurements, switch off the current of the electric circuit and discharge all capacitors.

1. Set the rotary switch to the $\Omega/\rightarrow+\rightarrow$ /CAP (20) position, then use the *MODE* button (15) to select the continuity test (*indication*).
2. Insert the plug of the red measuring tip into the *V/ Ω* measuring socket (5) and the plug of the black measuring tip into the *COM* measuring socket (6).
3. Connect the measuring lines to the circuit to be tested.
 - ⇒ When the circuit is closed and the resistance is smaller than 50 Ω , an acoustic signal is emitted.
 - ⇒ When the circuit is open, *OL* is displayed.

Diode testing



Warning of electrical voltage

Before carrying out resistance, continuity or diode measurements, switch off the current of the electric circuit and discharge all capacitors.

1. Set the rotary switch to the $\Omega/\rightarrow+\rightarrow$ /CAP (20) position, then use the *MODE* button (15) to select the diode test (*$\rightarrow+$* and *V* indication).
2. Insert the plug of the red measuring tip into the *V/ Ω* measuring socket (5) and the plug of the black measuring tip into the *COM* measuring socket (6).
3. Connect the measuring tips to the diode. If the *OL* indication (exceedance of the measuring range) is displayed, swap the measuring tip connections at the diode.
 - ⇒ The following indications may typically be displayed:
 - 0.400 to 0.700 V: Diode ok
 - indications near 0 V: Circuit short-circuited
 - OL: open circuit (in both polarities)

Example:

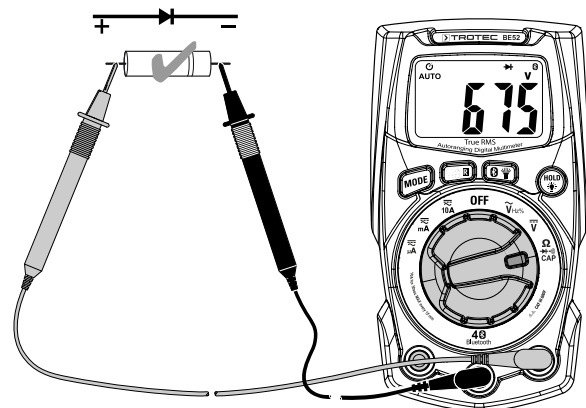

Measuring capacitance

Before carrying out capacitance measurements, observe the following:

- Discharge each capacitor before carrying out a measurement! Residual voltage in the capacitor can lead to a destroyed measuring device!
- Never connect the measuring inputs to a voltage source. This will destroy the measurement device.
- For reasons of safety, measure whether there is a residual charge in the capacitor (using the VDC range) before you perform a capacitance measurement.

1. Set the rotary switch to the Ω/\rightarrow /CAP position (20), then use the *MODE* button (15) to select the capacitance measurement (*nF* indication).
2. Insert the plug of the red measuring tip into the *V/ Ω* measuring socket (5) and the plug of the black measuring tip into the *COM* measuring socket (6).
3. Connect the capacitor to be tested to the measuring tips. Electrolytic capacitors must be connected with correct polarity (red to plus, black to minus).
Since the charging processes within the capacitor require a certain amount of time, the indication will be delayed by up to 3 minutes. This delay is systemic, not a malfunction. Wait until the displayed value has stabilized before reading the measured value.

⇒ The measured value will be indicated on the display.

Note:

In case of a defective capacitor zero will be displayed.

Bear in mind that electrolytic capacitors can come with a substantial scattering within their tolerance range.

Residual voltages in the capacitor or damaged insulating layers/dielectrics can lead to significantly falsified results.

Measuring frequency/duty cycle

1. Set the rotary switch to the $\tilde{V}_{Hz\%}$ position (18), then use the *MODE* button (15) to select the desired measurement mode (for frequency: *Hz* indication, for duty cycle: *%* indication).
2. Insert the plug of the red measuring tip into the *V/ Ω* measuring socket (5) and the plug of the black measuring tip into the *COM* measuring socket (6).
3. Connect the measuring tips to the measuring object.
⇒ Depending on the selection with the *MODE* button (15), the frequency or the duty cycle is shown.

Displaying the minimum / maximum value

The device comes with a maximum and minimum value indication.

You can call the maximum value saved by pressing the *MAX/MIN/R* button (16).

When you press the *MAX/MIN/R* button again, the device will show the minimum value saved.

Press the *MAX/MIN/R* button (16) for one second to exit the minimum / maximum value indication.



Setting the range



The device is provided with an auto-range function, this means that it adapts the indication of the decimal places and the unit to the measurement result. You can adapt the indication manually.

To do so, please proceed as follows:

1. Press the *MAX/MIN/R* button (16) for a long time.
⇒ The device exits the auto-range function and enables manual setting.
2. Repeatedly press the *MAX/MIN/R* button (16) briefly until the desired setting of the decimal places is displayed.
3. Carry out the measurements.
4. Return to the auto-range function by pressing the *MAX/MIN/R* button (16) for a long time.

Hold function

Press the *HOLD/*  button (3) to freeze the current measured value on the display. The symbol  on the display indicates the active Hold function.

Press the *HOLD/*  button again to exit the Hold function and return to the indication of the current measured value. The symbol  goes out.

Switching the display illumination on/off

Press the *HOLD/*  button (3) for a long time to switch on the display illumination.

Press the *HOLD/*  button again for a long time to switch off the display illumination again.

Switching the work light on/off

Press the  button (2) briefly to switch on the work light.

Press the  button briefly again to switch off the work light again.

Enabling or disabling Bluetooth

The device is provided with a Bluetooth function that allows you to connect the device with a terminal device (mobile phone, tablet, etc.) on which the MultiMeasure Mobile App is installed (see chapter *MultiMeasure Mobile App*).

Press the  button (2) for a long time to switch on the Bluetooth function.

Press the  button for a long time again to switch off the Bluetooth function again.

Switching the device off



Info

The device is switched off automatically after 15 minutes of non-use.

Set the rotary switch to the *OFF* position to switch off the device manually.

MultiMeasure Mobile app

MultiMeasure Mobile app



Install the Trotec MultiMeasure Mobile app on the terminal device you want to use in combination with the device.

Info

Some of the app's functions require access to your location and an active Internet connection.

The app is available for download in the Google Play Store as well as in Apple's app store and via the following link:



<https://hub.trotec.com/?id=43083>

Connecting a measuring device



Info

The app can simultaneously be connected to several different measuring devices or measuring devices of the same type and also record several measurements at the same time. The number of sensors that can be connected depends on the terminal device.

Proceed as follows to connect a measuring device to the terminal device:

- ✓ The Trotec MultiMeasure Mobile app is installed.
 - ✓ The Bluetooth function on your terminal device is activated.
1. Switch on the measuring device (see chapter Operation).
 2. Make sure that the Bluetooth function is activated on the measuring device.
 3. Start the Trotec MultiMeasure Mobile app on the terminal device.
 - ⇒ A list of active and available sensors will be displayed.

4. Press the button to refresh the display if the desired measuring device is not displayed as an active measuring device.
 - ⇒ The terminal device now searches all active sensors again and shows them on the display.

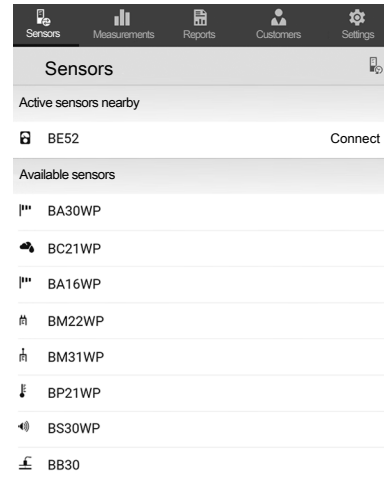

5. Select the desired sensor from the list of active sensors.
 - ⇒ The measuring device and the terminal device establish a connection with each other.
 - ⇒ The measured value indication appears on the display.

Measured value indication

When the sensor and the terminal device have established a successful connection, the submenu for the measurement will open and the display indicates the measuring mode set at the multimeter in a continuous measurement.

You can switch to a different measuring mode by setting the rotary switch at the multimeter to the desired measuring mode. For some measuring modes you additionally have to press the *MODE* button (see Operation chapter).

As an example, the screen for the AC voltage measuring mode is shown here:

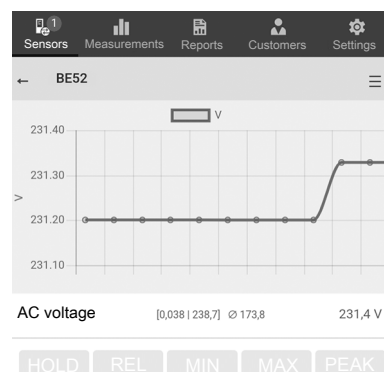

The last 12 values measured over time and the corresponding unit are displayed in the measured value field.

After several measurements have been carried out, the lowest value, highest value, average value and current value are displayed below the measured value field.

Measuring menu

Press the  button or the free area below the measurement value display to open the measuring menu at the bottom of the display. You can select from the following options in the measuring menu:

- reset the min/max average value
- switch over between X/T measurement (coordinate system) and the display of individual values
- terminate the connection to the sensor
- view and modify sensor settings
- start recording of measured values

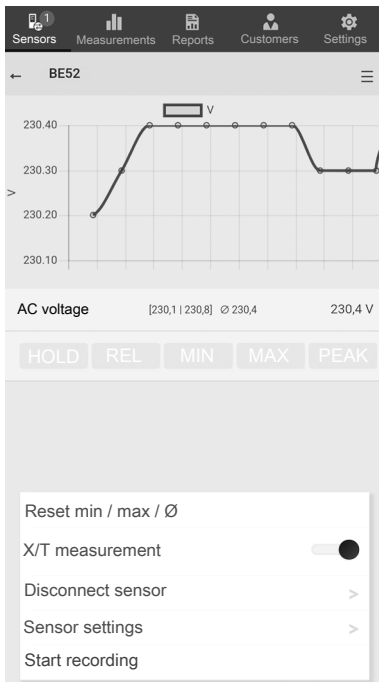

Display of individual values

After deactivation of the *X/T measurement* button, the display changes from continuous measurement to showing individual values.

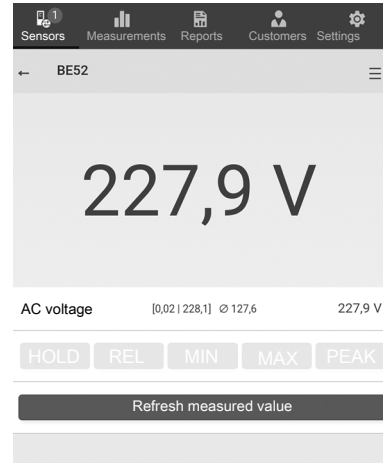

The current measured value and the corresponding unit are displayed in the measured value field.

After several measurements have been carried out, the lowest value, highest value, average value and current value are displayed below the measured value field.

By pressing the *Refresh measured value* button, you start a new measurement.

Recording measurements



Info

The minimum recording time is 30 seconds. If a measurement is interrupted or cancelled before this minimum measurement time has elapsed, it cannot be saved and may have to be performed again.

By actuating the *Start Recording* button, the app starts recording the measured values.

Instead of the  button, the symbol of the active sensor flashes to indicate that recording is in progress. You can press this flashing symbol or the free area below the measurement value display to open the context menu to stop recording.

You can choose from saving or discarding the record after stopping recording.

Menu bar

The functions of the MultiMeasure Mobile App are controlled via the menu bar from which the submenus can be accessed.



Info

Depending on the operating system of the terminal device, the menu bar is located at the top (Android) or bottom (IOS) of the display. In the further description the displays of the Android system are shown as an example.

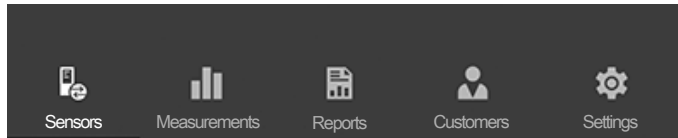

Designation	Function
Sensors	Opens the sensors overview. After connecting to the selected sensor, the submenu for the measurement opens.
Measurements	Opens the overview of saved measurements. The measurement series can be opened and edited.
Reports	Opens the overview of saved reports. You can generate on-site reports for the measurements and link them to customer data.
Customers	Opens the customers overview. You can select existing customers or create new customers.
Settings	Opens the settings menu. You can select the language and – depending on the measuring device – adjust different settings.

Submenu measurements

In the submenu *MEASUREMENTS*, the saved recordings of the measured values are displayed along with date, name and number of measuring points. Having selected the desired recording, the context menu of the measurement opens. Depending on the sensor type and the measuring mode, different functionalities can be opened. The following menu items are available:

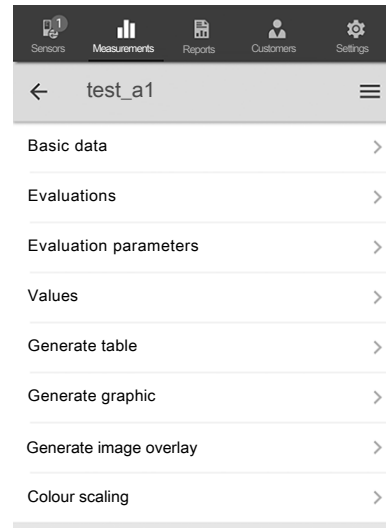

- **Basic data:**
Opens an overview of the data saved for the measurement.
- **Evaluations:**
Opens an overview of the evaluations generated for the measurement (photos, graphics and tables).
- **Evaluation parameters:**
Opens a menu to select and deselect individual evaluation parameters.
- **Values:**
Opens a tabular overview of all logged values for the measurement.
- **Generate table:**
Creates a table containing the logged values of the measurement and saves it as a *.CSV file.
- **Generate graphic:**
Creates a graphic representation of the logged values and saves it as a *.PNG file.
- **Generate image overlay:**
Combines a background image with the representation of the measured values.
- **Colour scaling:**
Allows you to adjust the colour display of the measured values.

Submenu reports

The reports generated in the MultiMeasure Mobile app are short reports providing a fast and simple documentation.

You can select from the following options in the *REPORTS* submenu:

- **Indicate existing reports:**
Having selected a report, a submenu opens where you can view and modify information.

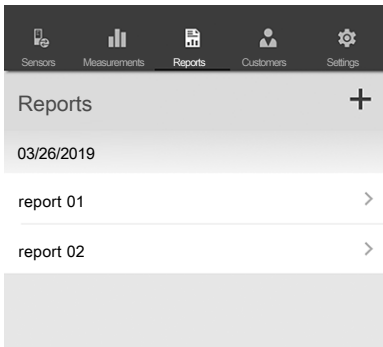

- **Generate a new report:**
Press the + button to open the input mask for a new report.

Submenu customers

Using the integrated customer management function all of the measured data can be assigned to specific clients via the app.

You can select from the following options in the *CUSTOMERS* submenu:

- **Call up an already created customer:**
Having selected a report, a submenu opens where you can view and modify information or directly start a measurement.

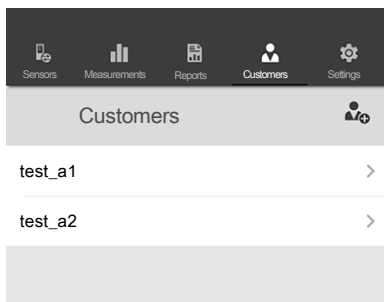

- **Creating a new customer:**
Press the + button to open the input mask for a new customer. You can create a new customer set or import an existing contact from the phone book of the terminal device.

Submenu settings

In the submenu *SETTINGS* you can adjust different settings, e.g. changing the menu language.



Note

The various sensors have slightly different setting options.

Example: Submenu *SETTINGS*:

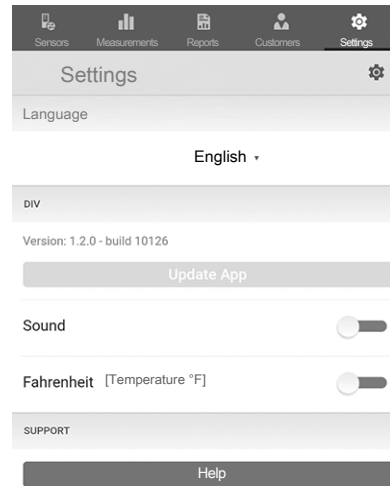

Maintenance and repair

Battery change



Info

In case of a low battery the displayed values may be inaccurate or incorrect! If so, stop using the measuring device and exchange the batteries immediately.

A battery change is required when the battery status indication displays an empty battery symbol, when incorrect measured values are displayed or when the device can no longer be switched on (see chapter Inserting the batteries).

Fuse replacement



Caution

Switch the device off and remove the measuring tips from the measuring sockets before opening the device! Internal fuses may only ever be replaced with fuses of the same type, never with one of a higher amperage or with a provisional solution! Otherwise the consequences include the risk of accidents, the destruction of the device and the loss of warranty.

Note

Only replace fuses of the same type!

1. Fold the stand at the rear of the device up.
2. Loosen the screw of the fuse compartment and remove the fuse compartment cover.
3. Remove the defective fuse.

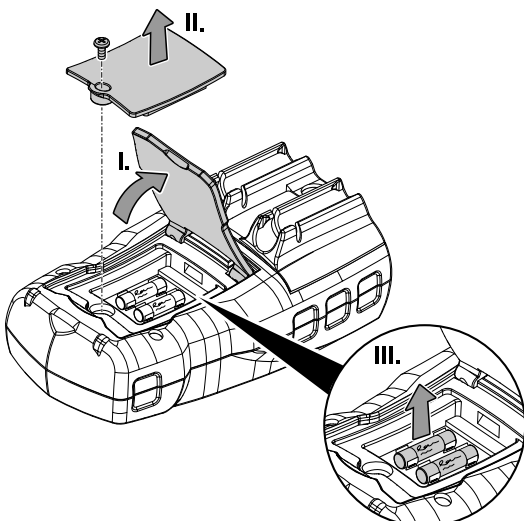

4. Insert a new fuse:
 - $\mu\text{A}/\text{mA}$ range: 500 mA / 600 V
 - 10 A range: 10 A / 600 V
5. Attach the cover and secure it by tightening the screw.
6. Fold back the stand.

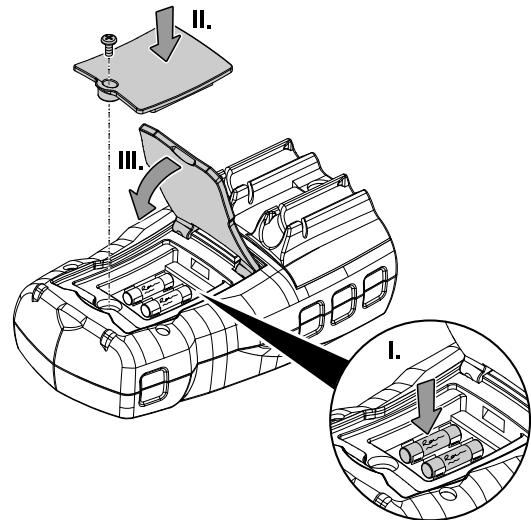

Cleaning

Clean the device with a soft, damp and lint-free cloth. Make sure that no moisture enters the housing. Do not use any sprays, solvents, alcohol-based cleaning agents or abrasive cleaners, but only clean water to moisten the cloth.

Repair

Do not modify the device or install any spare parts. For repairs or device testing, contact the manufacturer.

Errors and faults

The device has been checked for proper functioning several times during production. If malfunctions occur nonetheless, check the device according to the following list.

Display segments are only faintly visible or flicker:

- Do not perform another measurement or stop ongoing measurements immediately!
- The battery voltage is too low. Exchange the batteries immediately.

The device displays implausible measured values:

- Do not perform another measurement or stop ongoing measurements immediately!
- The battery voltage is too low. Exchange the batteries immediately.

Disposal

Always dispose of packing materials in an environmentally friendly manner and in accordance with the applicable local disposal regulations.



The icon with the crossed-out waste bin on waste electrical or electronic equipment is taken from Directive 2012/19/EU. It states that this device must not be disposed of with the household waste at the end of its life. You will find collection points for free return of waste electrical and electronic equipment in your vicinity. The addresses can be obtained from your municipality or local administration. You can also find out about other return options that apply for many EU countries on the website <https://hub.trotec.com/?id=45090>. Otherwise, please contact an official recycling centre for electronic and electrical equipment authorised for your country.

The separate collection of waste electrical and electronic equipment aims to enable the re-use, recycling and other forms of recovery of waste equipment as well as to prevent negative effects for the environment and human health caused by the disposal of hazardous substances potentially contained in the equipment.



In the European Union, batteries and accumulators must not be treated as domestic waste, but must be disposed of professionally in accordance with Directive 2006/66/EC of the European Parliament and of the Council of 6 September 2006 on batteries and accumulators. Please dispose of batteries and accumulators according to the relevant legal requirements.

Only for United Kingdom

According to Waste Electrical and Electronic Equipment Regulations 2013 (SI 2013/3113) (as amended) and the Waste Batteries and Accumulators Regulations 2009 (SI 2009/890) (as amended), devices that are no longer usable must be collected separately and disposed of in an environmentally friendly manner.

Declaration of conformity

We – Trotec GmbH – declare in sole responsibility that the product designated below was developed, constructed and produced in compliance with the requirements of the EU Radio Equipment Directive in the version 2014/53/EU.

Product model / Product: BE52

Product type: digital true RMS multimeter

Year of manufacture as of: 2022

Relevant EU directives:

- 2011/65/EU
- 2012/19/EU
- 2014/30/EU
- 2015/863/EU

Applied harmonised standards:

- EN 300 328 V2.2.2

Applied national standards and technical specifications:

- Regulation (EC) 1907/2006
- EN 61326-1:2013
- EN 61326-2-2:2013
- IEC 61000-4-4:2012
- EN IEC 61000-4-2:2008
- EN IEC 61000-4-3:2010
- EN IEC 61000-4-8:2009
- IEC 62321-3-1:2013
- IEC 62321-4:2013
- IEC 62321-5:2013
- IEC 62321-6:2015
- IEC 62321-7-1:2015
- IEC 62321-7-2:2017
- IEC 62321-8:2017

Manufacturer and name of the authorised representative of the technical documentation:

Trotec GmbH

Grebberer Straße 7, D-52525 Heinsberg

Phone: +49 2452 962-400

E-mail: info@trotec.de

Place and date of issue:

Heinsberg, 17.02.2023

Joachim Ludwig, Managing Director

Trotec GmbH

Grebener Str. 7
D-52525 Heinsberg

☎ +49 2452 962-400

☎ +49 2452 962-200

✉ info@trotec.com

www.trotec.com