

EN

INSTRUCTIONS
DIGITAL SOUND LEVEL METER



Table of contents

Information on the use of these instructions 2

Safety 2

Information about the device 4

Transport and storage 6

Operation 7

Software 10

Errors and faults 10

Maintenance and repair 11

Disposal 11

Information on the use of these instructions

Symbols

 **Warning of electrical voltage**
This symbol indicates dangers to the life and health of persons due to electrical voltage.

 **Warning**
This signal word indicates a hazard with an average risk level which, if not avoided, can result in serious injury or death.

 **Caution**
This signal word indicates a hazard with a low risk level which, if not avoided, can result in minor or moderate injury.

Notice
This signal word indicates important information (e.g. material damage), but does not indicate hazards.

 **Info**
Information marked with this symbol helps you to carry out your tasks quickly and safely.

 **Follow the manual**
Information marked with this symbol indicates that the instructions must be observed.

You can download the current version of the instructions and the EU declaration of conformity via the following link:



SL400



<https://hub.trotec.com/?id=43020>

Safety

Read this manual carefully before starting or using the device. Always store the manual in the immediate vicinity of the device or its site of use.

-  **Warning**
Read all safety warnings and all instructions. Failure to follow the warnings and instructions may result in electric shock, fire and/or serious injury.
Save all warnings and instructions for future reference.
- Do not use the device in potentially explosive rooms or areas and do not install it there.
 - Do not use the device in an aggressive atmosphere.
 - Do not immerse the device in water. Do not allow liquids to penetrate into the device.
 - The device may only be used in dry surroundings and must not be used in the rain or at a relative humidity exceeding the operating conditions.
 - Protect the device from permanent direct sunlight.
 - Do not expose the device to strong vibrations.
 - Do not open the device.
 - Do not remove any safety signs, stickers or labels from the device. Keep all safety signs, stickers and labels in legible condition.
 - Use batteries of type 6LR61 (9 V battery).
 - Never charge batteries that cannot be recharged.
 - Different types of batteries and new and used batteries must not be used together.
 - Insert the batteries into the battery compartment according to the correct polarity.
 - Remove discharged batteries. Batteries contain materials hazardous to the environment. Dispose of the batteries according to the national regulations.
 - Remove the batteries from the device if you will not be using the device for a longer period of time.
 - Never short-circuit the supply terminal in the battery compartment!

- Do not swallow batteries! If a battery is swallowed, it can cause severe internal burns within 2 hours! These burns can lead to death!
- If you think batteries might have been swallowed or otherwise entered the body, seek medical attention immediately!
- Keep new and used batteries and an open battery compartment away from children.
- Only use the device, if sufficient safety precautions were taken at the surveyed location (e.g. when performing measurements along public roads, on building sites etc.). Otherwise do not use the device.
- Observe the storage and operating conditions (see Technical data).
- Do not expose the device to directly squirting water.
- Check accessories and connection parts for possible damage prior to every use of the device. Do not use any defective devices or device parts.

Intended use

Only use the device for sound level measurements within the measuring range specified in the technical data.

Any use other than the intended use is regarded as misuse.

Reasonably foreseeable misuse

Do not use the device in potentially explosive atmospheres, for measurements in liquids or at live parts.

Any unauthorised changes, modifications or alterations to the device are forbidden.

Personnel qualification

People who use this device must:

- have read and understood the instructions, especially the Safety chapter.

Personal protective equipment



Wear hearing protection

Wear hearing protection when handling the device.

Residual risks



Warning of electrical voltage

There is a risk of a short-circuit due to liquids penetrating the housing!

Do not immerse the device and the accessories in water. Make sure that no water or other liquids can enter the housing.



Warning of electrical voltage

Work on the electrical components must only be carried out by an authorised specialist company!



Warning

Risk of hearing damage!

Ensure sufficient ear protection when there are sources of loud sound. There is a danger of hearing damage.



Warning

Risk of suffocation!

Do not leave the packaging lying around. Children may use it as a dangerous toy.



Warning

The device is not a toy and does not belong in the hands of children.



Warning

Dangers can occur at the device when it is used by untrained people in an unprofessional or improper way! Observe the personnel qualifications!



Caution

Keep a sufficient distance from heat sources.

Notice

To prevent damages to the device, do not expose it to extreme temperatures, extreme humidity or moisture.

Notice

Do not use abrasive cleaners or solvents to clean the device.

Information about the device

Device description

The digital sound level meter was specifically designed to perform noise measurements and quality inspections in various areas and different locations. The measurements can be carried out e.g. at your workplace, at the office, in factories, schools, at home or on busy roads. This permits the introduction of preventative measures and helps to guard against noise-induced diseases.

The device meets the requirements of the standard for digital sound level meters DIN EN 61672-1.

The device comes with the following functions:

- display of maximum and minimum values
- indication when exceeding the measuring range
- indication when falling below the measuring range
- dBA and dBC display
- measuring range selection
- data transfer to PC software via USB

Device depiction

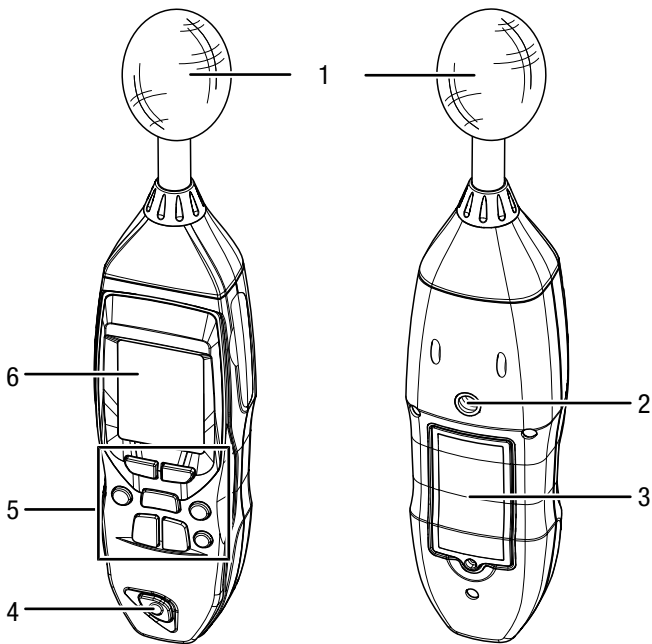

No.	Designation
1	Measuring probe with protective cap
2	Tripod thread
3	Battery compartment with cover
4	Power button
5	Control panel
6	Display

Control panel

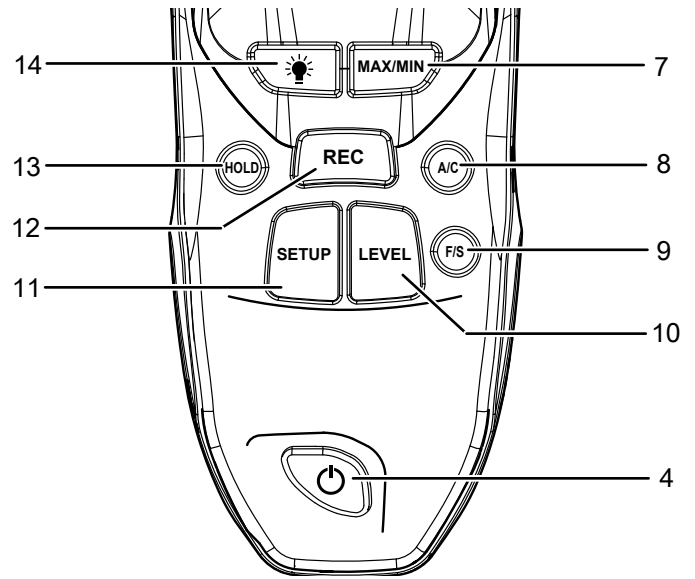

No.	Designation
4	Power button
7	MAX/MIN button
8	A/C button
9	F/S button
10	LEVEL button
11	SETUP button
12	REC button
13	HOLD button
14	Background illumination button

Display

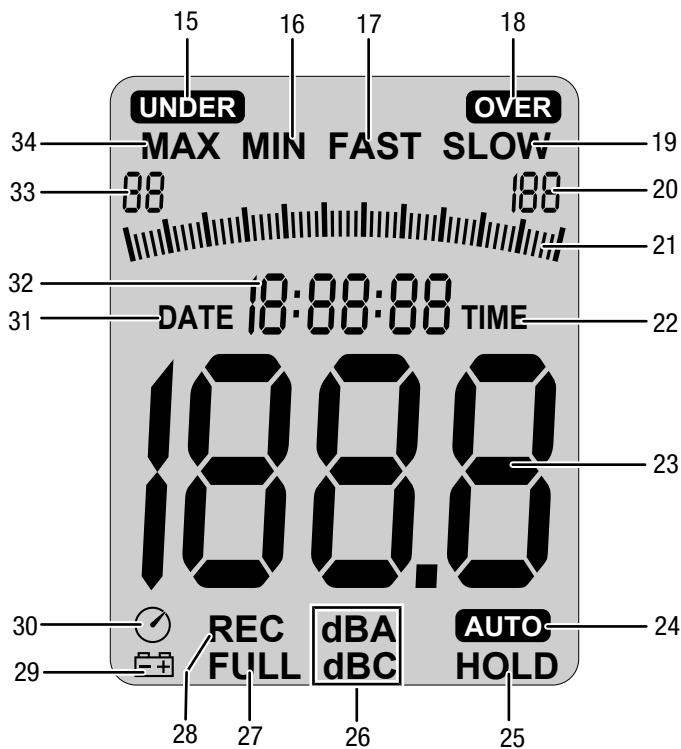

No.	Designation	Function
15	<i>UNDER</i> indication	Fallen below measuring range
16	<i>MIN</i> indication	Lowest measured value of the current measurement is shown in the measurement value display (23)
17	<i>FAST</i> indication	Fast signal evaluation: 125 ms
18	<i>OVER</i> indication	Measuring range exceeded
19	<i>SLOW</i> indication	Slow signal evaluation: 1 s
20	<i>Scale's maximum value</i> indication	Upper value of the current measuring range
21	<i>Scale</i> indication	Measured value relative to the measuring range
22	<i>TIME</i> indication	Menu for time setting active
23	Measurement value display	current measured value
24	<i>AUTO</i> indication	Automatic measuring mode selection active
25	<i>HOLD</i> indication	Last measured value is shown in the measurement value display (23)
26	<i>Measured curve</i> indication	Current measured curve: <i>dB(A)</i> <i>dB(C)</i>
27	<i>FULL</i> indication	Memory full

No.	Designation	Function
28	<i>REC</i> indication	Recording/saving active
29	<i>Battery status</i> indication	Flashes when the battery is low
30	<i>Automatic switch-off</i> indication	Automatic switch-off active
31	<i>DATE</i> indication	Menu for date setting active
32	<i>Time/date</i> indication	Time/date
33	<i>Scale's minimum value</i> indication	Lower value of the current measuring range
34	<i>MAX</i> indication	Highest measured value of the current measurement is shown in the measurement value display (23)

Connections

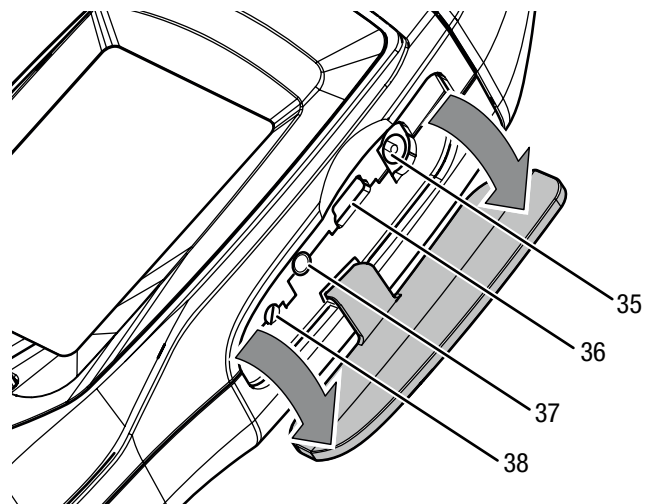

No.	Designation
35	Power adapter connection (DC 9 V)
36	Mini USB port
37	3.5 mm jack *
38	Setscrew for calibration **

* e.g. to connect a frequency analyser or recorder

** for service personnel only

Notice

The device is already factory-calibrated and optimally adjusted. A recalibration requires special tools. In the case of a recalibration please contact the Trotec service and do not carry out the calibration on your own.

Technical data

Parameter	Value
Model	SL400
Article number	3.510.005.020
Measuring range	30 dB to 130 dB
Accuracy	±1.4 dB (class 2 according to DIN EN 61672)
Resolution	0.1 dB
Frequency range	31.5 Hz to 8 kHz
Dynamic range	50 dB
Partial measuring ranges	30 dB to 80 dB, 50 dB to 100 dB, 80 dB to 130 dB, 30 dB to 130 dB
Display response time	500 ms
Power supply	9 V battery
Alarm function	OVER: measuring range exceeded UNDER: fallen below measuring range
Time weighting	FAST: 125 ms SLOW: 1 s
Microphone	1/2-inch electret condenser microphone
Operating conditions	0 °C to 40 °C with 10 % to 90 % RH
Storage conditions	-10 °C to +60 °C with 10 % to 75 % RH
Weight	305 g
Dimensions (length x width x height)	255 x 63 x 45 mm
Automatic switch-off	Switch-off after approx. 15 min of non-use

Scope of delivery

- 1 x Digital sound level meter SL400 (without battery)
- 1 x Wind shield for microphone
- 1 x Mini tripod
- 1 x CD with software
- 1 x USB cable
- 1 x Transport case
- 1 x Mini screwdriver
- 1 x Power adapter
- 1 x Quick guide

Transport and storage

Notice

If you store or transport the device improperly, the device may be damaged.

Note the information regarding transport and storage of the device.

Transport

For transporting the device, use the transport case included in the scope of delivery in order to protect the device from external influences.

Storage

When the device is not being used, observe the following storage conditions:

- dry and protected from frost and heat
- protected from dust and direct sunlight
- stored inside the transport case supplied in order to protect the device from external influences
- at the temperature specified in the technical data
- battery is removed from the device

Operation

Inserting the battery

Insert a suitable battery before first use.

Notice

Make sure that the surface of the device is dry and the device is switched off.

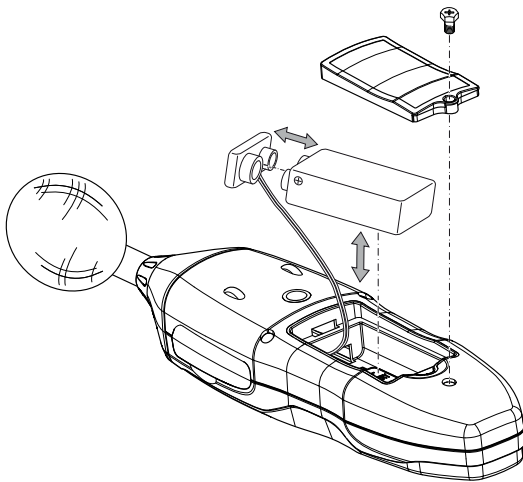

1. Open the battery compartment at the rear of the device by loosening the screw at the cover.
2. Use the battery clip to connect the 9 V battery with correct polarity.
3. Place the battery with the battery clip into the battery compartment.
4. Reattach the cover to the battery compartment.
5. Retighten the screw at the battery compartment.

Connecting the power adapter

For a permanent power supply, you can also operate the device using the power adapter supplied.

1. Connect the power adapter to the power adapter connection (35) on the device.
2. Connect the power adapter to a properly secured socket.

Switching the device and performing measurements



Info

Please note that moving from a cold area to a warm area can lead to condensation forming on the device's circuit board. This physical and unavoidable effect can falsify the measurement. In this case, the display shows either no measured values or they are incorrect. Wait a few minutes until the device has become adjusted to the changed conditions before carrying out a measurement.



Info

Please note that the measurement of a sound source always has to be carried out directly. There must be no objects or persons located in between the microphone and the sound source, unless their influence on the sound intensity is to be measured on purpose as well.

1. Press the *Power* button (4) for approx. 2 seconds.
 - ⇒ The display (6) is switched on and the device is ready for operation.
 - ⇒ The current measured value is displayed in the measurement value display (23) and on the scale (21). The measuring scale (21) corresponds to the needle display of an analogue measuring device.
2. Point the device at the sound source to be measured.
 - ⇒ Wait for a moment to achieve a stable measured value.

Setting the measuring range

The device has different measuring ranges which can be selected as needed or according to the expected sound level. If the expected sound level range is a known factor, one should always select the corresponding measuring range whenever possible, since this permits an optimum resolution of the scale (21) at all times.

- Lower measuring range: 30 to 80 dB
- Medium measuring range: 50 to 100 dB
- Upper measuring range: 80 to 130 dB
- Auto: 30 to 130 dB

Please proceed as follows to set the measuring range:

1. Repeatedly press the *LEVEL* button (10) until the desired measuring range is displayed on both ends of the scale (20 and 33).
 - ⇒ The scale will be adjusted automatically.
 - ⇒ *UNDER* (15) may be displayed if the measuring range has been fallen below or *OVER* (18) if the measuring range has been exceeded. In this case, adjust the measuring range again.

Measured curve setting (dBA / dBC)

You can choose whether your measured values are to be displayed according to dB(A) or dB(C).

Please proceed as follows to set the measured curve:

1. Repeatedly press the *A/C* button (8) until dB(A) or dB(C) is shown in the *Measured curve* indication (26).
⇒ The measured value will be adjusted automatically.

Setting the MAX / MIN function

By use of the MAX/MIN function you can retain either the highest or the lowest value of the current measurement. Please proceed as follows to set the MAX/MIN function:

1. Press the *MAX / MIN* button (7).
⇒ The *MAX* indication (34) appears on the display.
⇒ The measured value display (23) will be frozen and changes only if a new higher value is measured.
2. Press the *MAX / MIN* button (7) again.
⇒ The *MIN* indication (16) appears on the display.
⇒ The measured value display (23) will be frozen and changes only if a new lower value is measured.
3. Press the *MAX/MIN* button (7) again to quit using the MAX/MIN function.

Setting the HOLD function

By use of the HOLD function you can retain the currently measured value.

Please proceed as follows to set the HOLD function:

1. Press the *HOLD* button (13).
⇒ The *HOLD* indication (25) appears on the display.
⇒ The measured value display (23) will be frozen.
2. Press the *HOLD* button (13) again.
⇒ The currently measured value is indicated.
⇒ The *HOLD* indication (25) disappears.

Setting the time weighting

You can choose between a fast and slow time weighting. This function controls the speed at which the device processes an incoming sound signal and displays it as a measured value.

- FAST: 1/125 ms (real-time signal evaluation)
- SLOW: 1/s (average signal evaluation)

Please proceed as follows to set the time weighting:

1. Press the *F/S* button (9) until the desired indication *FAST* (17) or *SLOW* (19) is displayed.

Recording measurement series on the device (REC/Logging)



Info

You can only read out the saved measurement series using the *Sound Level Meter* software (see chapter Software).

Notice

The device can save several measurement series. If the memory is full, the *FULL* indication (27) appears. Delete some or all of the saved values to be able to save another measurement.

1. Press the *REC* button (12) to activate the device's recording function.
⇒ The *REC* indication (28) appears.
2. Press the *REC* button (12) again to stop recording measured values.
⇒ The measurement will be stored on the device memory with time and date.

Adjusting the saving interval of the device

- ✓ The device is switched off.
1. Press and hold the *Background illumination* button (14) and switch the device on.
⇒ *0001 Int* will be indicated in the measurement value display (23).
 2. Release the *Background illumination* button (14).
 3. Repeatedly press the *LEVEL* button (10) to adjust the saving interval between 0001 and 0059 seconds.
 4. Press the *HOLD* button (13) to save the setting.
⇒ The new saving interval is saved until the device is switched off.

Deleting data memory

- ✓ The device is switched off.
1. Press and hold the *REC* button (12) and switch the device on.
⇒ *CLR* will be indicated in the measurement value display (23).
⇒ All data records on the device memory will be deleted.
 2. Release the *REC* button (12).

Setting the time and date

You can adjust the time and date for the device.

You can save the settings and exit the menu at any time using the *HOLD* button (13).

To do so, please proceed as follows:

- ✓ The device is switched off.
- 1. Press and hold the *SETUP* button (11) and switch the device on.
 - ⇒ The *TIME* indication (22) lights up briefly.
- 2. Release the *SETUP* button (11).
 - ⇒ The *DATE* indication (31) appears.
 - ⇒ The *Time/date* indication (32) shows the currently set date in year:month:day format.
- 3. Press the *SETUP* button (11) again.
 - ⇒ The *TIME* indication (22) appears.
 - ⇒ The *Time/date* indication (32) shows the minutes.
- 4. Press the *LEVEL* button (10) to adjust the minutes.
- 5. Press the *SETUP* button (11) again.
 - ⇒ The *TIME* indication (22) appears.
 - ⇒ The *Time/date* indication (32) shows the hours. In the measurement value display (23), *h-P* stands for P.M. and *h-A* for A.M.
- 6. Press the *LEVEL* button (10) to adjust the hours.
- 7. Press the *SETUP* button (11) again.
 - ⇒ The *Time/date* indication (32) shows the day.
- 8. Press the *LEVEL* button (10) to change the day.
- 9. Press the *SETUP* button (11) again.
 - ⇒ The *DATE* indication (31) appears.
 - ⇒ The *Time/date* indication (32) shows the month.
- 10. Press the *LEVEL* button (10) to change the month.
- 11. Press the *SETUP* button (11) again.
 - ⇒ The *DATE* indication (31) appears.
 - ⇒ The *Time/date* indication (32) shows the year.
- 12. Press the *LEVEL* button (10) to change the year.
- 13. Press the *HOLD* button (13) to save the new time and date settings. If you do not want to save the settings made for time and date, press the *SETUP* button (11) again whilst in the display for setting the year.
 - ⇒ *rSt* will be indicated in the measurement value display (23).
- 14. To reset the settings for time and date to the factory default, press the *HOLD* button (13).
- 15. In order to return to the menu for setting time and date, press the *SETUP* button (11) when *rSt* is displayed.
 - ⇒ The next setting corresponds to the menu for adjusting the current date as described in step 3.

Setting the data transmission via USB

In order to transfer data for further analysis to a PC via USB, please proceed as follows:

1. Install the supplied software on your PC, see chapter Software.
2. Start the software.
3. Connect the PC and device via the supplied USB cable and the mini USB port (36).
4. Press the *SETUP* button (11) to activate both the real-time display of the device in the software interface and the data transfer mode.
 - ⇒ The automatic switch-off function will be deactivated for the duration of data transmission.
5. For the data transmission from the device to the PC please follow the instructions in the software help file.
6. Press the *SETUP* button (11) again to terminate the connection between device and PC.

Switching the background illumination on or off

The device comes with an optionally selectable background illumination.

1. Press the *Background illumination* button (14) to switch the background illumination on or off.

Assembling the tripod

The device is equipped with a 1/4 inch tripod thread (2). If required, you can mount the device on the supplied mini tripod or another suitable tripod.

Setting the automatic switch-off

The device comes equipped with an optional automatic switch-off function and switches off automatically if no button was pressed for approx. 15 minutes.

Please proceed as follows to activate or deactivate the automatic switch-off function:

- ✓ The device is switched on.
- 1. Press the *SETUP* button (11).
 - ⇒ The *Automatic switch-off* indication (30) appears on the display.
 - ⇒ The automatic switch-off function is activated.
- 2. Press the *SETUP* button (11) again to deactivate the automatic switch-off function.
 - ⇒ The *Automatic switch-off* indication (30) disappears.

Switching the device off

If the automatic switch-off function is enabled, the device switches off automatically if no button was pressed for approx. 15 minutes. Please proceed as follows to switch the device off:

1. Press and hold the *Power* button (4) until the device is switched off.
 - ⇒ A countdown from 3 to 1 is shown on the display.

Software

The supplied free *Sound Level Meter* software is designed for useful basic functionalities. Trotec assumes no liability with regard to this free software and also provides no support on that score. Trotec accepts no liability concerning the use of this free software and is under no obligation to make adjustments or to further develop updates or upgrades.

The software is available for download at www.trotec.de.

Installation requirements

Ensure that the following minimum requirements for installing the PC software are fulfilled:

- Supported operating systems (32 or 64 bit version):
 - Windows 10
 - Windows 8
 - Windows 7
 - Windows Vista
- Hardware requirements:
 - processor speed: min. 90 MHz
 - 32 MB RAM, minimum
 - 7 MB hard disk space, minimum
 - a minimum screen resolution of 1024 x 768 with a 16 bit colour depth

Installing the PC software

1. Insert the data medium with the software into the drive or download the current software from the Service area of Trotec download centre.
2. Double-click the *Setup.exe* file.
3. Follow the instructions of the installation wizard.

Starting the PC software

1. Connect the measuring device to your PC via the mini USB cable provided in the scope of delivery.
2. Switch on the measuring device if necessary.
3. Start the software.

Information about using the PC software is provided in the software help file.

Errors and faults

The device has been checked for proper functioning several times during production. If malfunctions occur nonetheless, check the device according to the following list.

The device does not switch on:

- Check the charging status of the battery. Change the battery, if required.
- Make sure that the battery is properly positioned. Check the polarity is correct.
- Never carry out an electrical check yourself; instead, contact your Trotec customer service.

Display segments are only faintly visible or flicker:

- Do not carry out any more measurements.
- The battery voltage is too low. Replace the battery immediately or connect the device to the power adapter.

The device displays implausible measured values:

- Do not carry out any more measurements.
- The battery voltage is too low. Replace the battery immediately or connect the device to the power adapter.
- The protective cap of the probe may be dirty or damaged. Check the protective cap of the probe.

Maintenance and repair

Battery change

A battery change is required when the *Battery status* indication (29) flashes or when the device can no longer be switched on (see chapter Inserting the battery).

Calibration

The device is already factory-calibrated and optimally adjusted. A recalibration requires special tools. In the case of a recalibration please contact the Trotec service and do not carry out the calibration on your own.

Cleaning

Clean the device with a soft, damp and lint-free cloth. Make sure that no moisture enters the housing. Do not use any sprays, solvents, alcohol-based cleaning agents or abrasive cleaners, but only clean water to moisten the cloth.

Repair

Do not modify the device or install any spare parts. For repairs or device testing, contact the manufacturer.

Disposal

Always dispose of packing materials in an environmentally friendly manner and in accordance with the applicable local disposal regulations.



The icon with the crossed-out waste bin on waste electrical or electronic equipment is taken from Directive 2012/19/EU. It states that this device must not be disposed of with the household waste at the end of its life. You will find collection points for free return of waste electrical and electronic equipment in your vicinity. The addresses can be obtained from your municipality or local administration. You can also find out about other return options that apply for many EU countries on the website <https://hub.trotec.com/?id=45090>. Otherwise, please contact an official recycling centre for electronic and electrical equipment authorised for your country.

The separate collection of waste electrical and electronic equipment aims to enable the re-use, recycling and other forms of recovery of waste equipment as well as to prevent negative effects for the environment and human health caused by the disposal of hazardous substances potentially contained in the equipment.



In the European Union, batteries and accumulators must not be treated as domestic waste, but must be disposed of professionally in accordance with Directive 2006/66/EC of the European Parliament and of the Council of 6 September 2006 on batteries and accumulators. Please dispose of batteries and accumulators according to the relevant legal requirements.

Only for United Kingdom

According to Waste Electrical and Electronic Equipment Regulations 2013 (SI 2013/3113) (as amended) and the Waste Batteries and Accumulators Regulations 2009 (SI 2009/890) (as amended), devices that are no longer usable must be collected separately and disposed of in an environmentally friendly manner.

Trotec GmbH

Grebener Str. 7
D-52525 Heinsberg

☎ +49 2452 962-400

☎ +49 2452 962-200

✉ info@trotec.com

www.trotec.com