

EN

OPERATING MANUAL
MOISTURE MEASURING
DEVICE



Table of contents

Notes regarding the operating manual..... 2

Safety 2

Information about the device..... 3

Transport and storage..... 4

Operation 5

Table of wood types 10

Measuring principle 10

PC software..... 14

Maintenance and repair 15

Errors and faults..... 15

Disposal 15

Notes regarding the operating manual

Symbols

 **Warning of electrical voltage**
This symbol indicates dangers to the life and health of persons due to electrical voltage.

 **Warning**
This signal word indicates a hazard with an average risk level which, if not avoided, can result in serious injury or death.

 **Caution**
This signal word indicates a hazard with a low risk level which, if not avoided, can result in minor or moderate injury.

Note
This signal word indicates important information (e.g. material damage), but does not indicate hazards.

 **Info**
Information marked with this symbol helps you to carry out your tasks quickly and safely.

 **Follow the manual**
Information marked with this symbol indicates that the operating manual must be observed.

You can download the current version of the operating manual and the EU declaration of conformity via the following link:



T510



<https://hub.trotec.com/?id=44143>

Safety

Read this manual carefully before starting or using the device. Always store the manual in the immediate vicinity of the device or its site of use.

-  **Warning**
Read all safety warnings and all instructions. Failure to follow the warnings and instructions may result in electric shock, fire and/or serious injury. **Save all warnings and instructions for future reference.**
- This appliance can be used by children aged from 8 years and above and persons with reduced physical, sensory or mental capabilities or lack of experience and knowledge if they have been given supervision or instruction concerning use of the appliance in a safe way and understand the hazards involved. Children shall not play with the appliance. Cleaning and user maintenance shall not be made by children without supervision.
- Do not use the device in potentially explosive rooms or areas and do not install it there.
 - Do not use the device in aggressive atmosphere.
 - Do not immerse the device in water. Do not allow liquids to penetrate into the device.
 - The device may only be used in dry surroundings and must not be used in the rain or at a relative humidity exceeding the operating conditions.
 - Protect the device from permanent direct sunlight.
 - Do not expose the device to strong vibrations.
 - Do not remove any safety signs, stickers or labels from the device. Keep all safety signs, stickers and labels in legible condition.
 - Do not open the device.
 - Observe the storage and operating conditions as given in the Technical data chapter.

Intended use

Only use the device to measure the moisture content of wood and other soft building materials (e.g. gypsum, plaster). Observe and comply with the technical data.

To use the device for its intended use, only use accessories and spare parts which have been approved by Trotec.

Improper use

Do not use the device in potentially explosive atmospheres, for measurements in liquids or at live parts.

Any unauthorised changes, modifications or alterations to the device are forbidden.

Personnel qualifications

People who use this device must:

- have read and understood the operating manual, especially the Safety chapter.

Residual risks



Warning of electrical voltage

There is a risk of a short-circuit due to liquids penetrating the housing!

Do not immerse the device and the accessories in water. Make sure that no water or other liquids can enter the housing.



Warning of electrical voltage

Work on the electrical components must only be carried out by an authorised specialist company!



Warning

Risk of suffocation!

Do not leave the packaging lying around. Children may use it as a dangerous toy.



Warning

The device is not a toy and does not belong in the hands of children.



Warning

Dangers can occur at the device when it is used by untrained people in an unprofessional or improper way! Observe the personnel qualifications!



Caution

Keep a sufficient distance from heat sources.

Note

To prevent damages to the device, do not expose it to extreme temperatures, extreme humidity or moisture.

Note

Do not use abrasive cleaners or solvents to clean the device.

Information about the device

Device description

The material moisture measuring device T510 enables the determination of the moisture content in wood and other soft building materials (e.g. gypsum, plaster) according to the resistance measurement method.

The device comes with two different types of measurement: for wood moisture on the one hand and for building moisture on the other. Different wood types or materials can be set for these measuring modes.

The device can be operated via a capacitive touchscreen control panel. When not in use, an automatic switch-off saves the battery.

Optionally, different electrodes can be connected via a separately available adapter set.

You can connect the device to a computer by using the USB cable included in the scope of delivery. Then you can extract and analyse your measured results with the optional MultiMeasure Studio software.

Device depiction

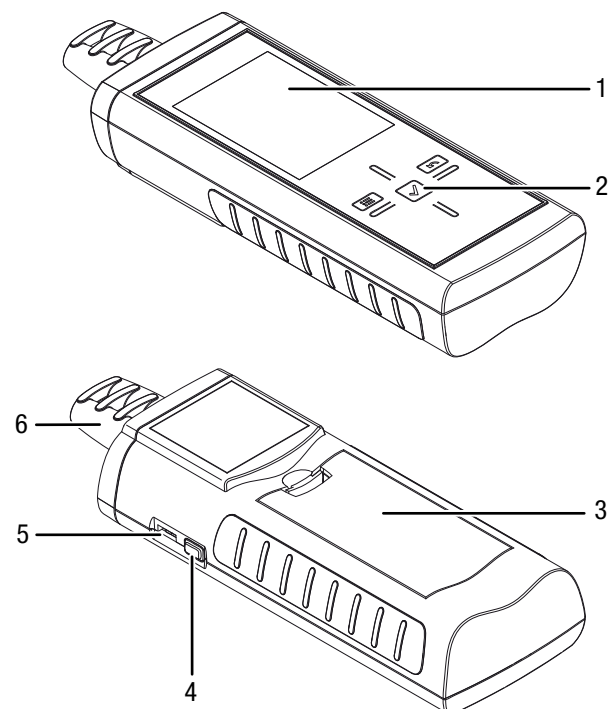

No.	Designation
1	Display
2	Cross control
3	Battery compartment with cover
4	Power button
5	USB interface
6	Connections for measuring tips with protective cap

Cross control

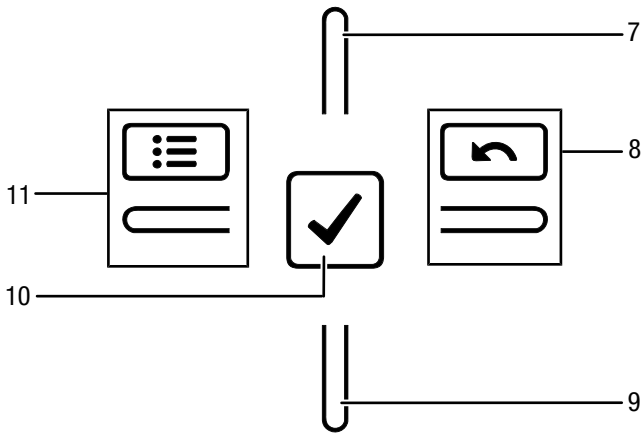

No.	Designation
7	Up button
8	Right/back button
9	Down button
10	OK button
11	Left/menu button

Display

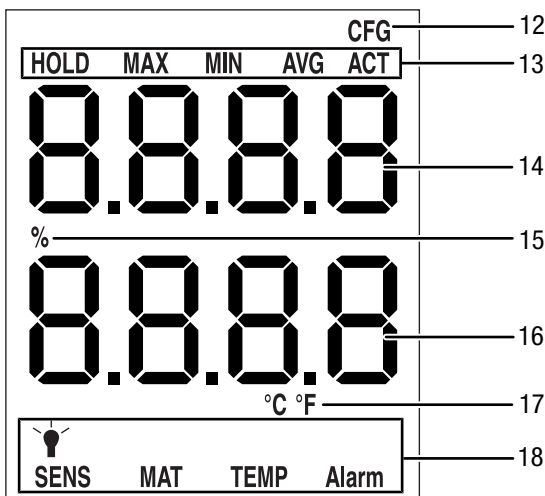

No.	Designation
12	CFG symbol (configuration mode display)
13	Measuring mode
14	Upper measured value indication (moisture)
15	Percentage indication
16	Lower measured value indication (temperature)
17	Temperature unit
18	Configuration mode

Technical data

Parameter	Value
Model	T510
Wood moisture	
Measuring range	0.0 to 100.0 M%
Accuracy	0 to 5 M%: ±0.8 M% 5 to 30 M%: ±0.2 M% 30 to 100 M%: ±0.1 M%
Temperature compensation	0.0 to 60.0 M%
Material moisture	
Measuring range	0 to 100 digits
Accuracy	0.1 digits
Resolution	0.1 digits
Penetration depth (coupling)	approx. 10 mm
General technical data	
Measuring method	resistance measuring method
Display	LCD
Interface	USB
Operating conditions	0 °C to 50 °C with < 90 % RH (non-condensing)
Storage conditions	-20 to 60°C at < 90 % RH (non-condensing)
Power supply	4 x 1.5 V, AA batteries
Weight	approx. 280 g
Dimensions (length x width x height)	187 mm x 63 mm x 35 mm

Scope of delivery

- 1 x Device T510
- 4 x 1.5 V batteries, type AA
- 1 x Protective cap
- 1 x Electrode tips (1.5 x 20 mm)
- 2 x Union nut
- 1 x Wood type directory
- 1 x Factory test certificate
- 1 x Quick guide

Transport and storage

Note

If you store or transport the device improperly, the device may be damaged. Note the information regarding transport and storage of the device.

Transport

When transporting the device, ensure dry conditions and protect the device from external influences e.g. by using a suitable bag.

Storage

When the device is not being used, observe the following storage conditions:

- dry and protected from frost and heat
- protected from dust and direct sunlight
- The storage temperature is the same as the range given in the Technical data chapter.
- Remove the batteries from the device.

Operation

Installing the measuring tips

Mount the measuring tips included in the scope of delivery before first use.

Note

Exclusively use the original measuring tips included in the scope of delivery. Other measuring tips might bend or damage the holder at the measuring device.

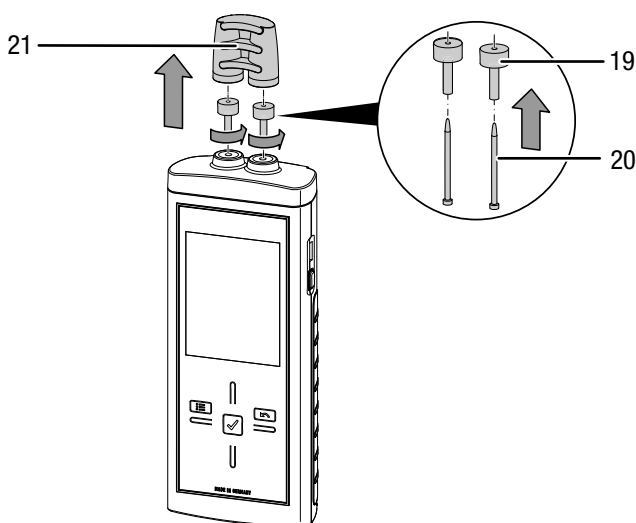

1. Remove the protective cap (21).
2. Detach the nuts (19)
3. Insert the measuring tips (20) in the nuts (19).
4. Refasten the nuts (19) on the device.

Inserting the batteries

Insert the supplied batteries before first use.



Caution

Make sure that the surface of the device is dry and the device is switched off.

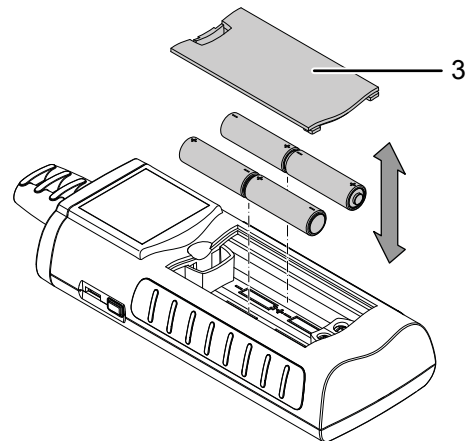

1. Remove the battery compartment cover (3).
2. Insert the batteries with correct polarity.
3. Insert the battery compartment cover (3).
⇒ The device can now be switched on.

Switch-on

Note:

The cross control is very sensitive. Therefore, avoid dirt on the control panel, because it could be misinterpreted by the device as keystroke.

Before use make sure that the touchscreen control panel is dirt-free.

If required clean the touchscreen control panel according to chapter *Cleaning the device*.

1. Press the On/Off button (4) until a beep is emitted.
⇒ The device performs a short self-test.
⇒ The device name and firmware version is shown on the display.
⇒ The battery charge is indicated on the display.
⇒ The device is ready for operation.
⇒ The displayed units are based on the settings of the last utilization.

Note:

Note that moving from a cold area to a warm area can lead to condensation forming on the device's circuit board. This physical and unavoidable effect can falsify the measurement. In this case, the display shows either no measured values or they are incorrect. Wait a few minutes until the device has become adjusted to the changed conditions before carrying out a measurement.

Performing the wood moisture measurement



Warning

When handling the device there is a risk of injury due to the exposed measuring tips. Always put on the protective cap when not in use.

Note

Never force the measuring device into the material to be measured or yank it out. Applying force can lead to bending or breaking of the measuring tips.

- ✓ The device is switched on.
 - ✓ The wood temperature is set.
 - ✓ The wood type is set.
1. Choose a suitable measuring position. The measurement is not to be performed at places with visible deficiencies (e.g. cracks, resin pockets, branches).
Further observe the following:
 - a = 30 cm
 - c = insertion depth
 - d = thickness

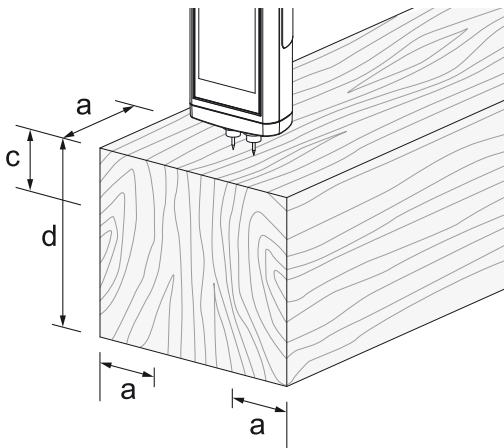

2. Insert the measuring tips transverse to the fibre direction with a 30 cm distance to one of the two ends of the sawn timber.
 - If the material to be measured is shorter than 60 cm, the measuring position is in the centre.
3. If possible, prick the measuring tips a few millimetres into the material.
4. Read the measured value from the upper measurement value display.
5. Carefully pull the device out of the material by gently moving it in turns to the left and to the right.

Performing the building moisture measurement



Warning

When handling the device there is a risk of injury due to the exposed measuring tips. Always put on the protective cap when not in use.

Note

Never force the measuring device into the material to be measured or yank it out. Applying force can lead to bending or breaking of the measuring tips.

- ✓ The device is switched on.
 - ✓ The measurement type for building moisture is set.
1. If possible, prick the measuring tips a few millimetres into the material.
 2. Read the measured value from the lower measurement value display.
 - For measured values of less than 15 digits the display reads: ----.
 - For measured values above 100 digits the display flashes.
 3. Carefully pull the device out of the material by gently moving it in turns to the left and to the right.

Key lock

1. Briefly press the On/Off key (4) during operation.
 - ⇒ The device emits a short beep.
 - ⇒ *LoC on* is indicated on the display.
 - ⇒ Key lock is activated.
2. Press the On/Off key (4) again.
 - ⇒ The device emits a short beep.
 - ⇒ *LoC off* is indicated on the display.
 - ⇒ Key lock is no longer activated.

Configuration mode

- Press the Left/menu key (11) for approx. 2 seconds.
 - ⇒ The device emits a short beep.
 - ⇒ The *CFG* symbol (12) is displayed in the upper right corner.
- Use the buttons on the cross control (2) to select the desired option.

Please note that some of the settings can only be selected with a certain measuring mode.

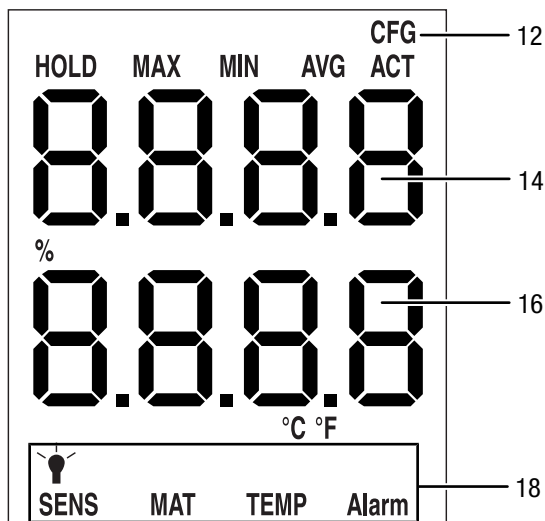

Configuration mode	Description
Lamp	Setting brightness. Available are values between 20 and 100 % and AL.on. Switch-off after 30 min unless with setting AL.on.
<i>SENS</i>	Selecting the sensor mode, available settings are Wood and Build.
<i>MAT</i>	Only available in sensor mode Wood. Selection of different wood types, see table of wood types.
<i>TEMP</i>	Only available in sensor mode Wood. Setting the value for wood temperature (fixed value only, no measurement, value range between -20 and +60 °C).
Alarm	Setting the alarm value. value range: 0 to 100 digits or M%
<i>CAL</i>	Setting the offset value. Will be added to the measured value. value range for the wood moisture measurement: -50 to +50 M% value range for the building moisture measurement: -50 to +50 digits

Setting the type of measurement

Here you can determine whether you want to measure wood or building moisture. You can choose from the settings *Wood 120* and *Build 100*.

- Select *SENS* whilst in configuration mode (18).
- Press the OK button (10) for approx. 2 seconds to confirm.
 - ⇒ The upper and lower measured value displays are flashing.
- Use the Up or Down key (9) to select the measurement type.
- Press the OK button (10) for approx. 2 seconds.
 - ⇒ The type of measurement was set based on your choice.
 - ⇒ The device switches to measuring mode.

Note:

How the measured values are indicated, changes depending on the type of measurement.

- Wood moisture:
 - Upper measurement value display: measured material moisture in %.
 - Lower measurement value display: preset material temperature in °C or °F.
- Building moisture:
 - Upper measurement value display: no indication.
 - Lower measurement value display: measured material moisture in digits.

Setting the alarm limit value

Here you can determine the limit value for the alarm function. Upon exceeding this value, the device emits an acoustic signal and the indication *ALARM* flashes in the configuration mode (18). The alarm function draws on the current measured value.

The limit value can be determined within a range of 0 to 100.

- Select *ALARM* whilst in configuration mode (18).
- Press the OK button (10) to confirm.
 - ⇒ The upper measurement value display (14) flashes.
- Press the Up (7) or Down (9) button to activate or deactivate the alarm.
 - ⇒ *On* or *Off* will be indicated in the upper measurement value display (14).
- Press the Right/back button (8).
 - ⇒ Depending on the selection, the alarm is either activated or deactivated.
 - ⇒ The lower measurement value display (16) flashes.
- Press the buttons Right/back (8) or Left/menu (11) to select a digit.
 - ⇒ The selected digit flashes.
- Press the Up (7) or Down (9) button to change the value of the selected digit.
- Repeat the steps 5. and 6. until the value is set as desired.
- Press the OK button (10) for approx. 2 seconds.
 - ⇒ The alarm was set based on your choice.

- ⇒ The device switches to measuring mode.
- ⇒ With activated alarm function the indication *ALARM* continues to be displayed in the configuration mode (18).

Adjusting the display illumination

The display illumination can be adjusted within a range of 20 to 100 %. Another available setting is *AL.on* (always on). *AL.on* features a brightness of 100 % and deactivates the automatic switch-off function.

1. Select the lamp (18) whilst in configuration mode.
2. Press the OK button (10) to confirm.
3. Select the desired value by use of the Up (7) or Down (9) button.
4. Press the OK button (10) for approx. 2 seconds.
 - ⇒ The set value will be adopted.
 - ⇒ The device switches to measuring mode.

Material settings



Note

Please note that this function can only be selected for wood moisture measuring.

1. Select *MAT* whilst in configuration mode (18).
2. Press the OK button (10) for approx. 2 seconds.
 - ⇒ *Code* will be indicated in the upper measurement value display.
 - ⇒ The current material code (see chapter Table of wood types) is indicated in the lower measurement value display.
3. Press the keys Right/back (8) or Left/menu (11) to select a digit.
 - ⇒ The selected digit flashes.
4. Press the Up (7) or Down (9) key to change the value of the selected digit.
5. Repeat the steps 3. and 4. until the value is set as desired.
6. Press the OK button (10) for approx. 2 seconds.
 - ⇒ The desired material is set.
 - ⇒ The device switches to measuring mode.

Setting the wood temperature



Note

Please note that this function can only be selected for wood moisture measuring.

Via this function you can determine the wood temperature in degrees Celsius (°C) or Fahrenheit (°F). The wood temperature is required by the device in order to determine the exact material moisture.

Note

Determine the wood temperature prior to the measurement, e.g. using a pyrometer.

1. Select *TEMP* whilst in configuration mode (18).
2. Press the OK button (10) for approx. 2 seconds.
 - ⇒ The currently set wood temperature is indicated in the lower measurement value display.
3. Use the buttons Left or Right to select a digit.
 - ⇒ The selected digit flashes.
4. Press the Up (7) or Down (9) key to change the value of the selected digit.
5. Repeat the steps 3. and 4. until the value is set as desired.
6. Press the OK button (10) for approx. 2 seconds.
 - ⇒ The wood temperature is set.
 - ⇒ The device switches to measuring mode.

Setting the offset

By use of *CAL* a single-point calibration can be carried out for the selected sensor indications. All sensors are already factory-calibrated and have a corresponding characteristic calibration curve. By stating a calibration value (offset) a global shift of the calibration curve, which has an effect on the entire measuring range, is performed for the single-point calibration! The offset value to be entered is that value by which the calibration curve will be shifted.

Example:

The displayed value is always "5" too high => change the offset value for this measurement channel to "-5".

The offset value's default setting is 0.0.



Note

Please note that changing the offset value brings about an automatic reset of the measured values.

1. Select *CAL* whilst in configuration mode (18).
2. Press the OK button (10).
3. Use the buttons Left or Right to select a digit.
 - ⇒ The selected digit flashes.
4. Press the Up (7) or Down (9) button to change the value of the selected digit.
5. Repeat the steps 3. and 4. until the value is set as desired.
6. Press the OK button (10) for approx. 2 seconds.
 - ⇒ The offset is set.
 - ⇒ The device switches to measuring mode.
 - ⇒ With set offset value the indication *CAL* continues to be displayed whilst in configuration mode (18).

Exiting configuration mode

Configuration mode will automatically be terminated after 8 seconds without entry.

You can quit configuration mode yourself anytime. Please note that in such an event no changes made to the settings will be adopted.

1. Press the Right/back key (8) for approx. 2 seconds.
 - ⇒ Configuration mode will be terminated.

Measuring mode

1. Press the keys Right/back (8) or Left/menu (11) until the desired measuring mode is displayed.
2. The selected measuring mode (13) will be indicated on the display (1)

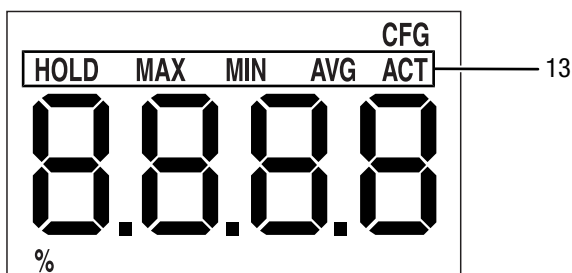

The device comes with the following measuring modes:

Measuring mode	Description
<i>ACT</i>	Measured value in real time
<i>AVG</i>	Average value of measurements since switch-on
<i>Min</i>	Minimum measured value
<i>Max</i>	Maximum measured value
<i>HOLD</i>	Measured value will be held

Holding the measured value

1. Set the measuring mode to *HOLD*.
 - ⇒ The current measured value will be held and displayed.
 - ⇒ The device will hold this value until the measured values are set back or the device is switched off.

Resetting the measured values

1. Press the OK button (10) for approx. 2 seconds.
 - ⇒ All previously stored measured values of the measuring modes *AVG*, *MIN*, *MAX* and *HOLD* will be set back.
 - ⇒ All previously stored measured values of the measuring modes *AVG*, *MIN*, *MAX* and *HOLD* will be set back.

Measured value storage

Please note that measured values cannot be saved on the device itself. In order to save measured values, the device has to be connected to a PC via a USB cable using the MultiMeasure Studio software.

1. Briefly press the OK button (10).

- ⇒ The displayed measured value will be saved in the software.

Further information can be gathered from the help text of the MultiMeasure Studio software.

Temperature display configuration



Note

Please note that this function can only be selected for wood moisture measuring.

1. Press the Up key (7) to switch between °C and °F.
 - ⇒ The temperature will be displayed in the selected unit.
 - ⇒ The unit (15) will be indicated on the display (1).

USB interface

The device can be connected to a PC via the USB interface (5). See chapter *PC software*.

Switch-off

1. Press and hold the On/Off button (4) for approx. 3 seconds until a beep is emitted.
 - ⇒ The device is switched off.

Connecting external electrodes

An adapter set and adapter cable are required to connect external electrodes. For further information please contact the TROTEC® customer service.

Connecting adapter set and adapter cable

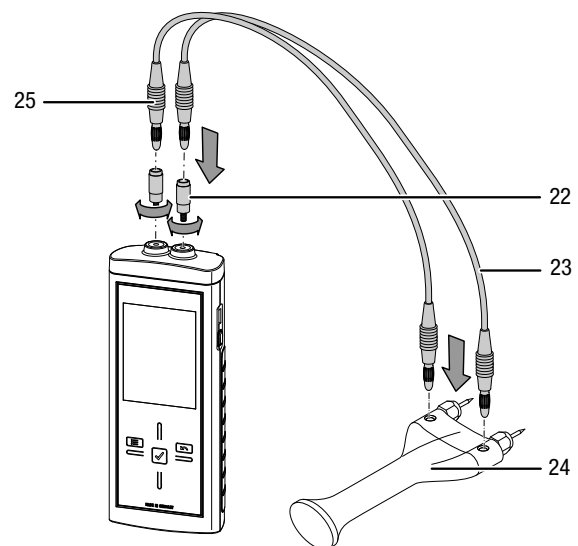

1. Detach the nuts and remove the measuring tips, if applicable.
2. Screw the two adapters (22) onto the device.
3. Plug the two cable ends (25) of the adapter cable (23) into the adapters (22).
 - ⇒ You can now connect external electrodes (example: (24)) to the device.
 - ⇒ Observe the condition of the external electrodes and prepare these for the measurement, if required.
 - ⇒ For further information on suitable electrodes please contact the TROTEC® customer service.

Table of wood types

The tables of wood types included in the scope of delivery contains approx. 200 types of wood with their corresponding material codes. The following tables contains all the material codes stored within the device incl. typical examples of wood types:

Material code H-	Wood type examples
1	pine; pitch pine, control code
2	Cembra pine
3	Meranti, dark red
4	poplar, silver, white poplar
5	birch, yellow, silver, sweet/black; wood fibre insulating boards; cherry
6	spruce, Norway
7	chipboard urea; wenge
8	maple (sycamore), Scottish maple, acer, sugar maple; acacia; yew; alder; ash; spruce Central Europe; chestnut, sweet, buckeye; mahogany sapele, Philippines; Meranti, light red; walnut; plum; pine, red; robinia, locust; elm; Kauramin chipboard; cypress
9	larch; limba
10	Gaboon; mahogany, genuine, big-leaf, Okoumé; walnut, American black; Padauk; plane
11	woodfibre hardboard; lime, basswood
12	Douglas fir; oak, red oak, northern red, English oak, durmast oak; Oregon pine
13	rosewood, shisham
14	beech, common
15	pear; beech, common hornbeam, European; oak, white oak, Arizona; buckeye, American chestnut; mecrussé (Lebombo ironwood); olive; chipboard isocyanate; teak
16	mahogany Gaboon
17	Nargusta
18	bamboo light
19	red ironwood
20	oak, holm oak
21	ash, American ash
22	cocus wood (granadillo)
23	bamboo dark, melamine-faced chipboard
24	doussie (Afzelia)
25	iroko (African teak); kambala
26	ebony, African, black
27	cork; chipboard phenolic resin
28	(see table of wood types printed version)
29	(see table of wood types printed version)
30	(see table of wood types printed version)
31	(see table of wood types printed version)
32	(see table of wood types printed version)
33	(see table of wood types printed version)
34	(see table of wood types printed version)
35	(see table of wood types printed version)

Measuring principle

During moisture measurement according to the resistance principle an electric measuring current is generated within the measuring device, which is conducted through the material to be measured by means of electrodes.

With an increasing water content of the measured material to be examined the resistance drops and conductivity builds up.

If the material to be measured has a high resistance, the moisture content is low.

If the material to be measured has a low resistance, the moisture content is high.

Thus, moisture measurement according to the resistance principle is an indirect measurement method, since the humidity is deduced from the conductivity of the measured material.

Wood moisture measurement

Every type of wood has a distinct conductivity. In order to take this fact into consideration for the measurement, every wood type comes with a material code that can be set.

The wood's conductivity is further influenced by the wood temperature. In order to take this fact into consideration for the measurement, the wood temperature can also be determined.

The wood temperature is to be determined before moisture measurement and set accordingly.

The measuring device comes equipped with an internal temperature compensation. The resistance curves of the selected wood type are automatically adapted depending on the set wood temperature.

Error sources

During resistance measurement the accuracy of the measurement method needs to be examined. Two fundamental types of error sources become apparent within the measuring range from 0 to 100 M%.

- There is one error stemming from the measuring principle of the resistance measurement. This is particularly noticeable in case of high resistance values (low conductivity at less than 5 M%). Due to the low measuring currents the measurement value display is i.a. increasingly falsified by molecular attraction. Listed below are the principle-related measurement errors:

Measured value	Error
0 - 5 M%	0.8 M%
6 - 30 M%	0.2 M%
31 - 100 M%	0.1 M%

- The other typical error source to be considered is material characteristics. This is particularly noticeable in case of high moisture contents above the fibre saturation point (high conductivity above 30 M%). Owing to the irregular cellular structure of various wood types and the i.a. resulting irregular water retention within and outside of the cells, these measured values in part substantially deviate from the actual moisture contents. It is, however, not possible to put a precise number on these deviations, even though the principle-related accuracies with 0.1 M% suggest a higher accuracy than for the medium measuring range from 6 to 30 M%.

When looking at both error sources, one can conclude, that the resistance measurement method is particularly well suited for the determination of the moisture content between 6 and 30 M%.

Notes regarding the wood moisture measurement

- Make sure you have set the correct type of measurement (wood).
- Make sure that the correct material code was selected.
- Prior to the actual measurement process, check the temperature conditions. To do so, for instance a pyrometer is to be used for measuring the surface temperature of the wood type, which should then be compared with the wood temperature set in the device. If both temperatures are identical, measuring can be started.
If the wood temperature is higher than the value set in the measuring device, a higher wood moisture than really there will be displayed as a result.
- When measuring sawn timber, observe the instructions of DIN EN 13183-2.
- Always insert the measuring tips transverse to the wood fibre direction.
The conductivity transverse to the wood fibre direction is lower than that in line with it.
Depending on the type of wood it varies by the factor 2.3 to 8.
- When selecting the measuring positions observe the following:
 - Always measure the material moisture at three different positions in order to achieve a sufficient accuracy by means of the arithmetic average.
 - Do not measure the face, because there are mainly dry areas.
 - Preferably do not measure at cracks, branches or resin pockets either.
- Oily and/or aqueous timber preservatives affect the measurement result.
- If possible, do not measure wood with a temperature below -5 °C. Too low wood temperatures distort the result of the measurement.

- Avoid static charge of the material to be measured due to friction. Static charge distorts the measurement result.
- With a wood moisture of less than 10 %, electrostatic forces can appear at the good to be measured. This can falsify the result of the measurement. Experience has shown that this occurs at the outlet of veneer drying plants. Remove the static charge by use of suitable grounding measures.
- The temperature value set within the device must be identical to the wood temperature.
Example:
With a set temperature value of 20 °C and a wood temperature of 30 °C the measurement result would be distorted upwards by approx. 1.5 %.
- The measurement's accuracy depends on the contact pressure of the measuring tips. The measuring tips must be connected to the wood in a way that the contact resistance is small as compared to the measuring resistance.
- The measurement results ought to be checked on a sample basis by means of the Darr test.

Building moisture measurement

The electric conductivity of a dry, mineral construction material (e.g. cementitious screed) is very low. When the building material absorbs water, the conductivity of the material can quickly increase or the resistance decrease.

What needs to be considered for the assessment of the measurement results is that the results are affected by the material composition of the measured goods:

- The presence of soluble salts can distort the measurement result substantially.
The more salt is present, the higher will be the displayed measurement value.
- Yet another variable for the evaluation of the results is the connection of the electrodes with the construction material. In case of mineral, porous building materials, slight electrode contact can cause a comparatively high contact resistance. This can falsify the result of the measurement.

The accuracy of the measurement results is thus lower for mineral construction materials than for wood.

Building moisture measurements allow only qualitative conclusions about the moisture (dry, damp, wet).

Quantitative conclusions about the moisture content of the mineral material to be measured can only be drawn by applying the Darr procedure or the CM method.

Notes regarding the building moisture measurement

- Make sure you have set the correct type of measurement (build).
- For measuring, the temperature of the building material ought to be in the range of 20 °C.
- Observe disruptive influences due to electrically conducting salts in the material:

Building-related moisture issues often occur in liaison with water-soluble salts. Salts further the conductivity of construction materials. During the measurement, the building material has a lower resistance value. Consequently, a too high measured value will be displayed.

- Observe disruptive influences due to electrically conducting substances:

If a construction material contains electrically conducting substances, it also has a lower resistance value, which then simulates high moisture values. Consequently, a too high measured value will be displayed.

From visual inspection it is usually not apparent, whether there are any electrically conducting substances inside the construction material. Some of the main error sources here are in particular reinforcements, metal laminations and conducting insulation such as slag in timber beam ceiling constructions. Especially in case of insulation materials with metal lamination, measured values are often misinterpreted during the resistance measurement.

Measured value assessment building moisture measurement

For the measured value assessment of building material, the measurement results of the resistance measuring method can only be used as reference for a rough orientation.

Conclusions with respect to absolute humidity in mass % (M%) can only be drawn for measurements, performed with the exact same marginal conditions and compositions of the building material as indicated for the test set-up in the chart below.

This graph was created in collaboration with the Institute of Building Materials Research of the RWTH Aachen (IBAC) and illustrates the correlation between the measured value and the mass-related moisture content of the examined building materials. The presentation of the metrological results in this form now permits a proper comparison of the measured value and the actual moisture content. The list is limited to the most commonly used mineral building materials. The measured values relate to a reference temperature of 23 °C.

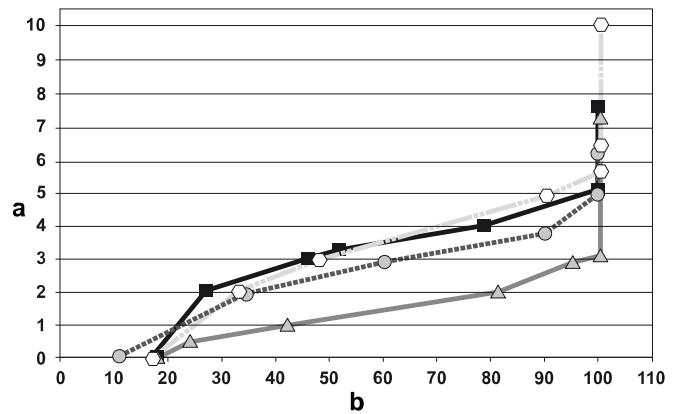

Key	
a	Moisture content (M%)
b	Measured value (digits)
---○---	C 30/37 concrete (conversion not possible)
—■—	Cementitious screed (conversion: CM% = M% - 1.5 to 2)
---○---	Cementitious floating screed (conversion not possible)
---△---	Anhydrite floating screed (conversion: M% = CM%)

Plaster

The determination of the moisture content of plaster calls for separate examination. As can be seen from the following chart, the volume-based moisture content of plaster changes little at air humidity values between 0 and 0.8 (80 %). However, when exceeding the level of 0,8 (80 %), the moisture content skyrockets.

Sorption isotherm of plaster:

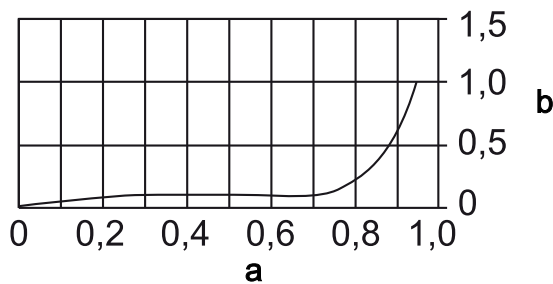

Key	
a	Relative humidity ψ
b	Water content u_v in %

This was also confirmed by the calibration measurements of the Institute of Building Materials Research (IBAC). Therefore, one can conclude, that a direct correlation between measured value and mass-related moisture content is not possible. As sufficient criterion for the classification of the measured values it can however be stated, that plaster can be considered dry, when the measured resistance value is smaller than 30 digits. When evaluating the measured values it is imperative to observe that different marginal conditions prevail for every measurement.

Important variables influencing the worth of the measured value are the connection of the electrodes to the material to be measured, the material temperature, the construction material's composition, salt loading and aggregates.

For construction materials not listed, usually sufficient conclusions can be drawn owing to local reference values. As a consequence, the affected damp area can be narrowed down to such an extent that a comparative measurement is carried out at an evidently dry wall or floor area as basis of valuation.

By use of the higher measured values of the area to be assessed, the spreading of the damp area can well be determined.

Reference values for the assessment of areas damaged by water

In case of water damage a resistance measurement can be carried out to enable an evaluation of the area to be dried. Based on the factual moisture content and the changeable marginal conditions, the following table can be used to assess the necessity for drying by use of technical means.

Here, one has to observe that the measurement results constitute only one component of a comprehensive damage diagnosis. The experience of the evaluator and local circumstances play just as vital a role as the documentation of the measurement results. The documentation further allows to demonstrate the success of a technical drying procedure.

Digit scale values	*	**	***
<i>Insulation layers / packed bed</i>			
polystyrene (particle foam)	< 36	36 to 50	> 50
polystyrene hard foam (extruded)	< 36	36 to 50	> 50
polyurethane hard foam	< 36	36 to 50	> 50
glass fibre	< 36	36 to 45	> 45
rock wool or slag wool	< 36	36 to 45	> 45
silicate foam glass	< 36	36 to 50	> 50
cork, expanded volcanic rock	< 31	31 to 40	> 40
wood-wool slabs	< 41	41 to 50	> 50
clay fill	< 41	41 to 55	> 55
coir	< 36	36 to 40	> 40
<i>Building materials</i>			
Anhydrite screed	< 36	36 to 50	> 50
Cement screed	< 36	36 to 50	> 50
wood cement screed	< 36	36 to 50	> 50
xylolith	< 41	41 to 55	> 55
Plaster	< 31	31 to 40	> 40
*	dry – no drying required		
**	threshold – drying may be required after evaluation of the damage characteristics		
***	thorough moisture penetration – drying by use of technical means required		
All values are approximations and without warranty.			

PC software

Use the MultiMeasure Studio Standard PC software (free standard version) or MultiMeasure Studio Professional (paid professional version, dongle required) to carry out a detailed analysis and visualisation of your measured results. You can only use all configuration, visualisation and functional options of the device when using this PC software and a TROTEC® USB dongle (professional).

Installation requirements

Ensure that the following minimum requirements for installing the MultiMeasure Studio Standard or MultiMeasure Studio Professional PC software are fulfilled:

- Supported operating systems (32 or 64 bit version):
 - Windows XP from service pack 3
 - Windows Vista
 - Windows 7
 - Windows 8
 - Windows 10
- Software requirements:
 - Microsoft Excel (to display stored Excel files)
 - Microsoft .NET Framework 3.5 SP1 (is automatically installed during software installation, where applicable)
- Hardware requirements:
 - Processor speed: 1.0 GHz, minimum
 - USB connection
 - Internet connection
 - 512 MB RAM, minimum
 - 1 GB hard disk space, minimum
 - optional: TROTEC® USB dongle (Professional) for using the professional version of the PC software

Installing the PC software

1. Download the current PC software from the Internet. To do so, visit the website www.trotec.de. First click on products and services, then on services and downloads. Then select Software in the category menu. Select the MultiMeasure Studio Standard software from the list. If you want to use the optionally available professional version of the PC software "MultiMeasure Studio Professional" (dongle), then get in touch with your TROTEC® customer service.
2. Double-click on the downloaded file to start the installation.
3. Follow the instructions of the installation wizard.

Starting the PC software

1. Connect the device to your PC via the USB connection cable provided in the scope of delivery.

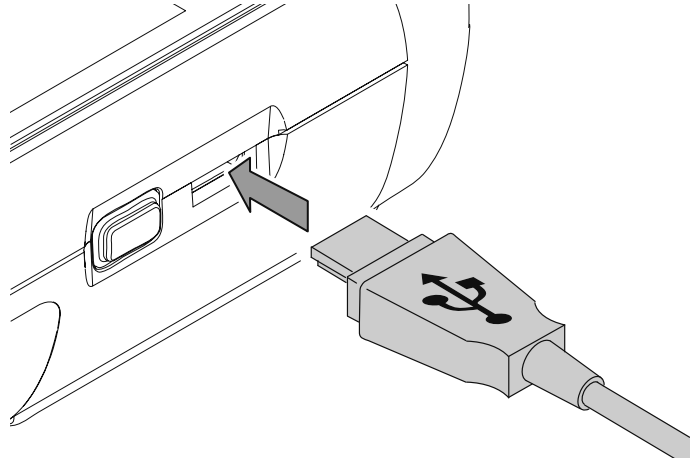

Note

Step 2 only needs to be performed, when using the Professional software functions.

If you only use the Standard software functions, please proceed to step 3.

2. In order to enable the Professional functions, connect the TROTEC® USB dongle to a free USB port on your PC. The TROTEC® USB dongle (Professional) is automatically detected by the operating system. If you only connect the TROTEC® USB dongle (Professional) to your PC after starting the PC software, click the "Parameters" menu item in the PC software. Afterwards, click the USB symbol (dongle check) to read the connected TROTEC® USB dongle (Professional).
3. Switch the device on (see chapter *Switch-on and measurements*).
4. Start the MultiMeasure Studio software. Depending on the activation process you will be asked to insert the access code that has been previously assigned to you. Only then the dongle for releasing the according Professional tools of the software will be activated.



Note

Information regarding the use of the MultiMeasure Studio software is provided in the help text of the software.

Maintenance and repair

Battery change

Change the batteries when the message *Batt lo* is displayed upon switch-on or the device can no longer be switched on. See chapter Operation *Inserting the batteries*.

Exchanging measuring tips

Exchange the measuring tips when these exhibit signs of wear (e.g. oxidation, heavy contamination). See chapter *Operation, Installing the measuring tips*.

Note:

The device's measuring tips are bordered by use of special cap nuts and screwed in place. A slight clearance within the nuts is intended. To avoid peak load, it is possible that the tips loosen somewhat after a few measurements. Hence, regularly check the cap nuts for tight fit and, if required, retighten them by hand. In order to avoid damage to the threads, please do not use any tools such as pliers when doing so.

Cleaning

Clean the device with a soft, damp and lint-free cloth. Make sure that no moisture enters the housing. Do not use any sprays, solvents, alcohol-based cleaning agents or abrasive cleaners, but only clean water to moisten the cloth.

Repair

Do not modify the device or install any spare parts. For repairs or device testing, contact the manufacturer.

Errors and faults

The device has been checked for proper functioning several times during production. If malfunctions occur nonetheless, check the device according to the following list.

The device does not switch on:

- Check the charging status of the batteries. Change the batteries when the message *Batt lo* is displayed upon switch-on.
- Check that the batteries are properly positioned. Check the polarity is correct.
- Never carry out an electrical check yourself; instead, contact your TROTEC® customer service.

Disposal



The icon with the crossed-out waste bin on waste electrical or electronic equipment stipulates that this equipment must not be disposed of with the household waste at the end of its life. You will find collection points for free return of waste electrical and electronic equipment in your vicinity. The addresses can be obtained from your municipality or local administration. For further return options provided by us please refer to our website <https://de.trotec.com/shop/>.

The separate collection of waste electrical and electronic equipment aims to enable the re-use, recycling and other forms of recovery of waste equipment as well as to prevent negative effects for the environment and human health caused by the disposal of hazardous substances potentially contained in the equipment.



In the European Union, batteries and accumulators must not be treated as domestic waste, but must be disposed of professionally in accordance with Directive 2006/66/EC of the European Parliament and of the Council of 6 September 2006 on batteries and accumulators. Please dispose of batteries and accumulators according to the relevant legal requirements.

Trotec GmbH

Grebener Str. 7
D-52525 Heinsberg

☎ +49 2452 962-400

☎ +49 2452 962-200

✉ info@trotec.com

www.trotec.com