

# EN

INSTRUCTIONS  
THERMOHYGROMETER



**Table of contents**

**Information on the use of these instructions** ..... 2

**Safety** ..... 2

**Information about the device** ..... 4

**Transport and storage** ..... 8

**Start-up** ..... 8

**Operation** ..... 9

**Errors and faults** ..... 13

**Maintenance and repair** ..... 14

**Disposal** ..... 14

**Declaration of conformity** ..... 15

**Information on the use of these instructions**

**Symbols**

 **Warning**  
This signal word indicates a hazard with an average risk level which, if not avoided, can result in serious injury or death.

 **Warning of electrical voltage**  
This symbol indicates dangers to the life and health of persons due to electrical voltage.

 **Caution**  
This signal word indicates a hazard with a low risk level which, if not avoided, can result in minor or moderate injury.

**Notice**  
This signal word indicates important information (e.g. material damage), but does not indicate hazards.

 **Info**  
Information marked with this symbol helps you to carry out your tasks quickly and safely.

 **Follow the manual**  
Information marked with this symbol indicates that the instructions must be observed.

You can download the current version of these instructions via the following link:



BZ290S



<https://hub.trotec.com/?id=47050>

**Safety**

**Read this manual carefully before starting or using the device. Always store the manual in the immediate vicinity of the device or its site of use.**

 **Warning**  
**Read all safety warnings and all instructions.**  
Failure to follow the warnings and instructions may result in electric shock, fire and/or serious injury.  
**Save all warnings and instructions for future reference.**

- Do not use the device in potentially explosive rooms or areas and do not install it there.
- Do not use the device in an aggressive atmosphere.
- Do not immerse the device in water. Do not allow liquids to penetrate into the device.
- The device may only be used in dry surroundings and must not be used in the rain or at a relative humidity exceeding the operating conditions.
- Protect the device from permanent direct sunlight.
- Do not expose the device to strong vibrations.
- Do not open the device.
- Do not remove any safety signs, stickers or labels from the device. Keep all safety signs, stickers and labels in legible condition.
- Use batteries of type LR06 (AA).
- Never charge batteries that cannot be recharged.
- Different types of batteries and new and used batteries must not be used together.
- Insert the batteries into the battery compartment according to the correct polarity.
- Remove discharged batteries. Batteries contain materials hazardous to the environment. Dispose of the batteries according to the national regulations.
- Remove the batteries from the device if you will not be using the device for a longer period of time.
- Never short-circuit the terminals of batteries!

- Do not swallow batteries! If a battery is swallowed, it can cause severe internal burns within 2 hours! These burns can lead to death!
- If you think batteries might have been swallowed or otherwise entered the body, seek medical attention immediately!
- Keep new and used batteries and an open battery compartment away from children.
- Observe the storage and operating conditions (see Technical data).

### Intended use

The device is used to measure and display weather data of indoor and outdoor areas.

Set up the display unit indoors.

The outdoor unit can be installed outdoors. It must not be exposed to rain or direct sunlight.

Observe and comply with the technical data.

Any use other than the intended use is regarded as misuse.

### Reasonably foreseeable misuse

Do not use the device in potentially explosive atmospheres, for measurements in liquids or at live parts.

Any unauthorised changes, modifications or alterations to the device are forbidden.

### Personnel qualification

People who use this device must:

- have read and understood the instructions, especially the Safety chapter.

### Residual risks



#### Warning

There is a danger of suffocation for children due to packaging material! Keep packaging films and parts away from children. There is a risk of death due to suffocation.



#### Warning of electrical voltage

There is a risk of a short-circuit due to liquids penetrating the housing!  
Do not immerse the device and the accessories in water. Make sure that no water or other liquids can enter the housing.



#### Warning of electrical voltage

Work on the electrical components must only be carried out by an authorised specialist company!



#### Warning

The device is not a toy and does not belong in the hands of children.



#### Warning

Dangers can occur at the device when it is used by untrained people in an unprofessional or improper way! Observe the personnel qualifications!



#### Caution

Keep a sufficient distance from heat sources.

#### Notice

To prevent damages to the device, do not expose it to extreme temperatures, extreme humidity or moisture.

#### Notice

Do not use abrasive cleaners or solvents to clean the device.

**Information about the device**

**Device description**

The device BZ290S is a thermohygrometer used to measure the relative humidity level and temperature in indoor and outdoor areas.

It has a display unit that is placed indoors and an outdoor unit that is placed outdoors. The temperature and humidity level in the outdoor area are both displayed on the outdoor unit and transmitted to the display unit via radio.

The device also has other functions, including a time and date display, a weather forecast and an alarm clock. The time is received via the radio waves of the DCF77 transmitter.

The display unit is operated with a mains cable. As an alternative, battery operation is also possible. The outdoor unit is battery-operated.

**Device depiction**

**Display unit**

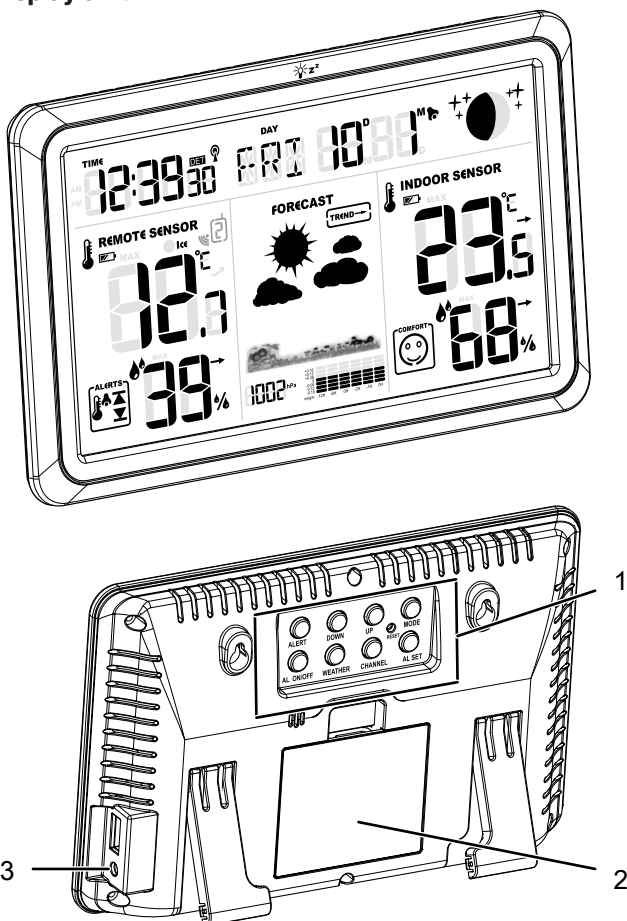

Item	Designation
1	Operating elements of the display unit
2	Battery compartment cover of the display unit
3	Power adapter connection of the display unit

**Outdoor unit**

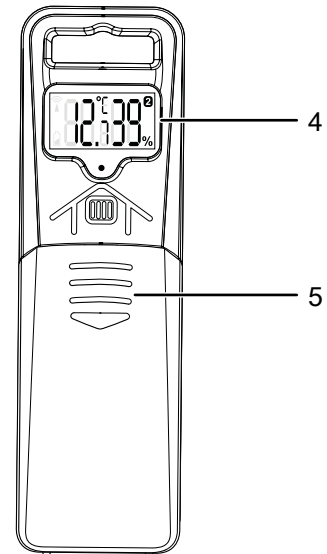

Item	Designation
4	Display of the outdoor unit
5	Battery compartment cover of the outdoor unit

### Operating elements of the display unit

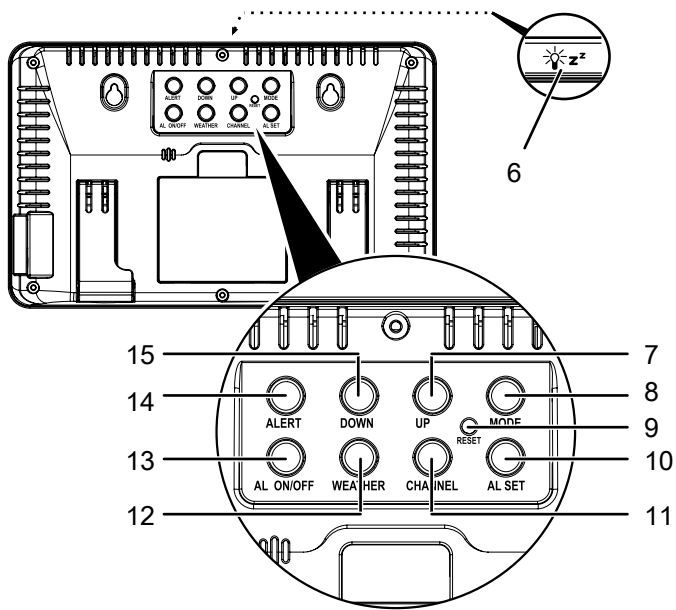

Item	Button	Meaning
6	<i>SNOOZE</i> (front of device)	Activate snooze function, switch illumination on and off
7	<i>UP</i>	Increase value, go to next setting
8	<i>MODE</i>	Make date settings
9	<i>RESET</i>	Reset to factory settings
10	<i>AL SET</i>	Set alarm clock
11	<i>CHANNEL</i>	Change transmission channel of display unit
12	<i>WEATHER</i>	Change temperature unit for indoor temperature, make weather settings
13	<i>AL ON/OFF</i>	Switch alarm clock on and off
14	<i>ALERT</i>	Set temperature alarm
15	<i>DOWN</i>	Decrease value, go to previous setting

### Operating elements of the outdoor unit

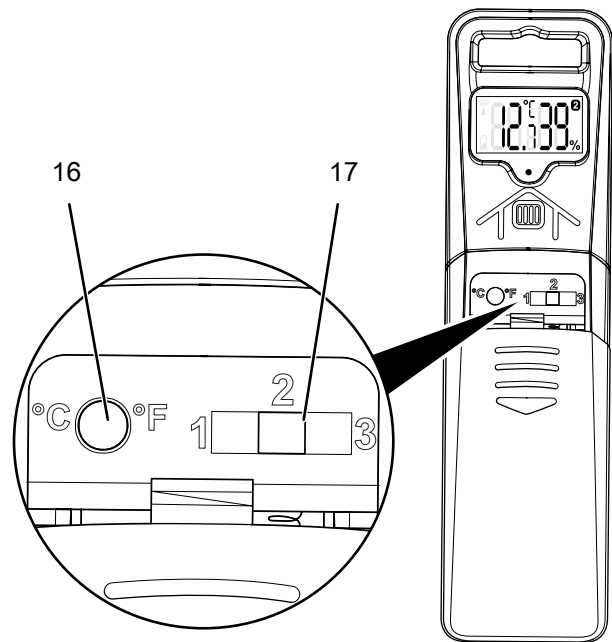

Item	Operating element	Meaning
16	<i>Temperature unit</i> button	Change temperature unit for outdoor temperature
17	<i>Transmission channel</i> slider	Change transmission channel of outdoor unit

**Display of the display unit**

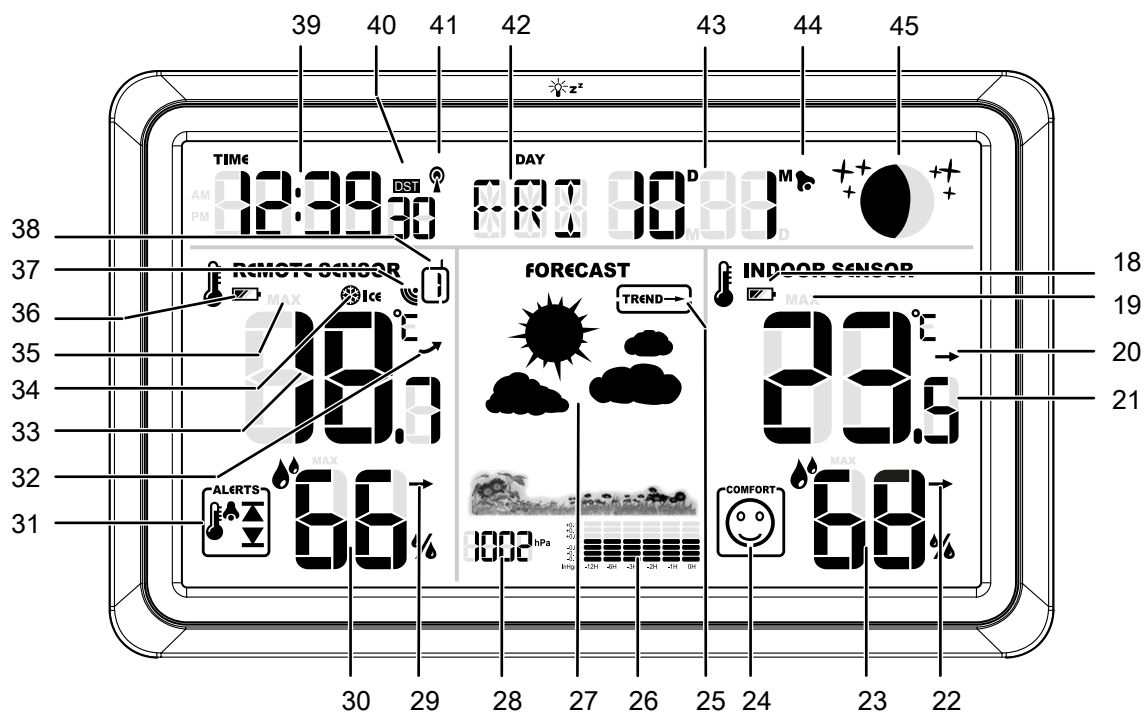

Item	Indication	Meaning
18	Battery status indoor	Battery charge status of the display unit
19	MAX/MIN indoor	Illuminated when the daily maximum/minimum temperature is displayed
20	Indoor temperature trend	Trend of indoor temperature
21	Indoor temperature	Current indoor temperature
22	Indoor humidity trend	Trend of indoor humidity level
23	Indoor humidity	Current indoor humidity level
24	Comfort	Impacts of temperature and relative humidity on human well-being
25	Air pressure trend	Trend of atmospheric pressure
26	Air pressure history	Past air pressure measurements
27	Weather forecast	Weather forecast
28	Air pressure	Current air pressure
29	Outdoor humidity trend	Trend of outdoor humidity level
30	Outdoor humidity	Current outdoor humidity level
31	Alarm status	Status of temperature alarms
32	Outdoor temperature trend	Trend of outdoor temperature
33	Outdoor temperature	Current outdoor temperature

Item	Indication	Meaning
34	Frost warning	Illuminated when there is a risk of frost
35	MAX/MIN outdoor	Illuminated when the daily maximum/minimum temperature is displayed
36	Battery status outdoor	Battery charge status of the outdoor unit
37	Connection status outdoor unit	Illuminated when there is a connection to the outdoor unit
38	Transmission channel	Channel used for connection to the outdoor unit
39	Time	Current time
40	DST	Illuminated when daylight saving time is activated
41	DCF77 status	Illuminated when the DCF77 signal has been successfully retrieved
42	Weekday	Current day of the week
43	Date	Current date
44	Alarm clock	Illuminated when the alarm clock is activated
45	Moon phase	Current moon phase

## Display of the outdoor unit

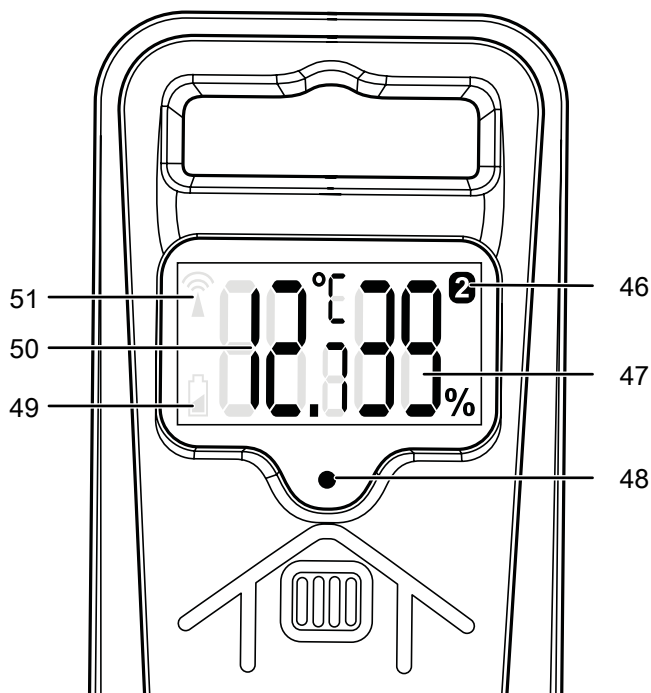

Item	Indication	Meaning
46	<i>Outdoor unit transmission channel</i>	Channel used for connection to the display unit
47	<i>Outdoor unit humidity</i>	Current outdoor humidity level
48	<i>Indicator LED</i>	Illuminated while information is being transmitted to the display unit
49	<i>Battery status outdoor unit</i>	Illuminated when a battery change is required
50	<i>Outdoor unit temperature</i>	Current outdoor temperature
51	<i>Transmission signal</i>	Illuminated while information is being transmitted to the display unit

## Technical data

Parameter	Value
Model	BZ290S
Relative humidity measuring range	1 to 99 % RH
Indoor temperature measuring range	-9.9 to +50 °C
Outdoor temperature measuring range	-40 to +70 °C
Accuracy – humidity	±2 % RH (at 40 to 80 % RH) ±3 % RH (at 30 to 39 % RH and 81 to 90 % RH) ±5 % RH (at 1 to 29 % RH and 91 to 99 % RH)
Accuracy – temperature	±0.5 °C
Radio frequency (outdoor unit)	433 MHz
Range (outdoor unit)	100 m
Maximum transmission capacity	7.43 dBm
Operating conditions (display unit)	9.9 °C – 50 °C < 99 % RH
Operating conditions (outdoor unit)	-40 °C – 70 °C < 99 % RH
Storage conditions (display unit)	-9.9 °C – 50 °C < 70 % RH
Storage conditions (outdoor unit)	-10 °C – 50 °C < 70 % RH
Power supply	display unit: 3 x Battery AA, 1.5 V (LR06) outdoor unit: 2 x Battery AA, 1.5 V (LR06)
Dimensions (W x H x D)	display unit: 197 x 123 x 27 mm outdoor unit: 40 x 133 x 27 mm
Weight	0.445 kg

## Scope of delivery

- 1 x Display unit (without batteries)
- 1 x Power adapter
- 1 x Outdoor unit (without batteries)
- 1 x Quick guide

## Transport and storage

### Notice

If you store or transport the device improperly, the device may be damaged.

Note the information regarding transport and storage of the device.

### Transport

When transporting the device, ensure dry conditions and protect the device from external influences e.g. by using a suitable bag.

### Storage

When the device is not being used, observe the following storage conditions:

- dry and protected from frost and heat
- protected from dust and direct sunlight
- with a cover to protect it from invasive dust if necessary
- at the temperature specified in the technical data
- Batteries are removed from the device

## Start-up

### Inserting batteries into the display unit

Insert the batteries into the device before first use.

### Notice

Make sure that the surface of the device is dry and the device is switched off.

The display unit is intended to be operated with mains power. As it can also be operated with batteries as an alternative or to bridge a power failure, the batteries must first be inserted as follows:

1. Open the battery compartment cover (2).
2. If applicable, remove the old batteries.
3. Insert the new batteries in the battery compartment with correct polarity.
4. Then close the battery compartment cover again.

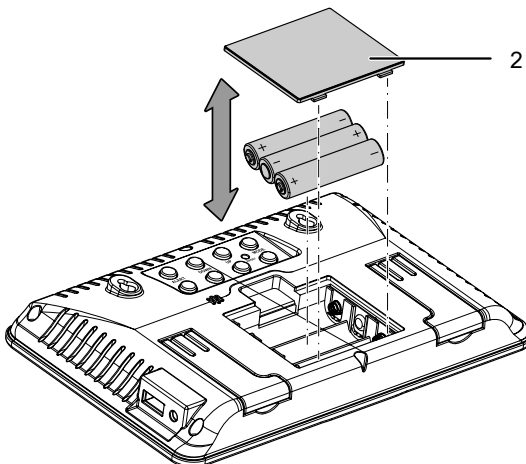

### Connecting the power adapter

Connect the display unit to the mains using the supplied power adapter.

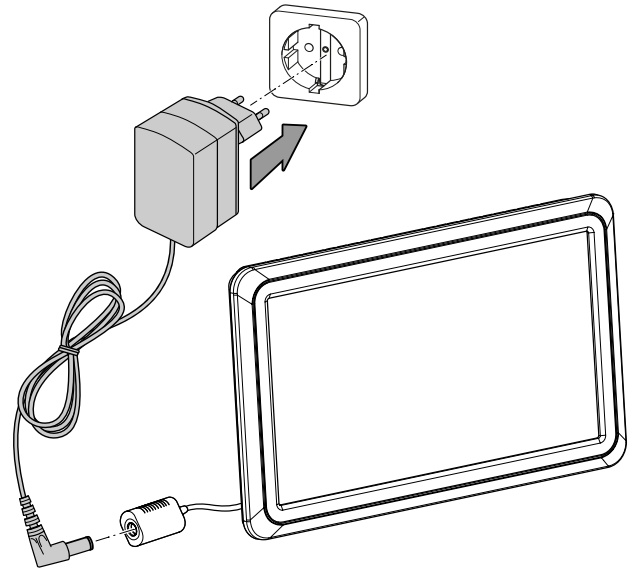

### Inserting batteries into the outdoor unit

The outdoor unit is battery-operated. Insert the batteries as follows:

1. Open the battery compartment cover of the outdoor unit (5) by sliding it in the direction of the arrow.
2. If applicable, remove the old batteries.
3. Insert the new batteries in the battery compartment with correct polarity.
4. Slide the battery compartment cover in the opposite direction to the arrow to close it.

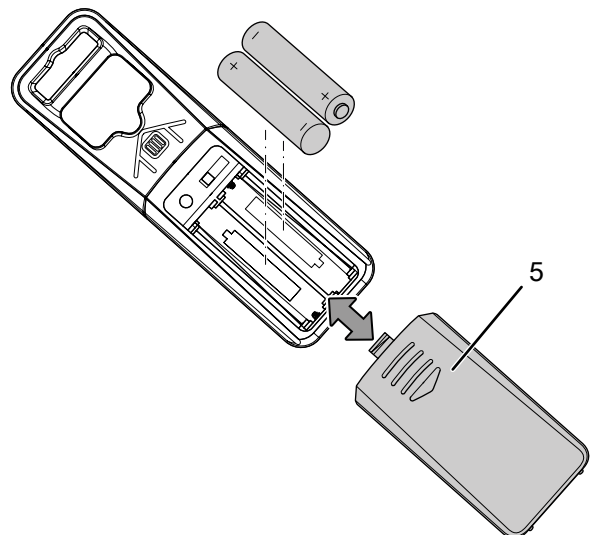

## Connecting display unit and outdoor unit

Once the power supply of both units has been established, the units connect automatically within 3 minutes and the outdoor unit starts sending data to the display unit. The *connection status outdoor unit* indication (37) flashes.

If the connection is not established automatically, make sure that both units are using the same transmission channel:

1. Open the battery compartment cover of the outdoor unit (5) by sliding it in the direction of the arrow.
2. Slide the *transmission channel* slider (17) to the desired channel between 1 and 3.
3. Repeatedly press the *CHANNEL* button (11) on the display briefly until the *transmission channel* indication (38) shows the same channel as the outdoor unit.
4. Press the *CHANNEL* button (11) on the display unit for 2 seconds.
  - ⇒ The *connection status outdoor unit* indication (37) flashes.
  - ⇒ The display unit searches for a nearby outdoor unit that is transmitting on the selected channel.
  - ⇒ Once the display unit has found an outdoor unit, its values are displayed.
5. Press the *CHANNEL* button (11) on the display unit for 2 seconds.
  - ⇒ The connection has been successfully established.
  - ⇒ The *connection status outdoor unit* indication (37) is permanently illuminated.
  - ⇒ The *transmission signal* indication (51) and the *indicator LED* (48) light up when data is being transmitted to the display unit.
6. Slide the battery compartment cover in the opposite direction to the arrow to close it.

## Automatic time setting via radio

As soon as the connection to the outdoor unit has been established, the display unit starts searching for the radio signal of the DCF77 transmitter for automatic time setting. The *DCF77 status* indication (41) flashes. During the search, the screen is automatically switched off so as not to disturb the reception of the radio signal. The process takes about 7 minutes.

If the time setting has been received successfully, the time (39) and the *DCF77 status* indication (41) will be permanently illuminated.

If the time setting could not be received, the unit will search for the radio signal every hour until reception has been successful.

Once the radio signal has been received, the unit will always search for the radio signal between midnight and 5:00 a.m. only. Generally, the unit receives the radio signal every day at 1:00, 2:00 and 3:00 a.m. If reception was unsuccessful, another two attempts will be made at 4:00 and 5:00 a.m.

## Operation

Before positioning the device, observe the following:

- Do not expose to direct sunlight.
- Do not position directly above a heater.
- If possible, position at an interior wall; avoid cooler exterior walls.

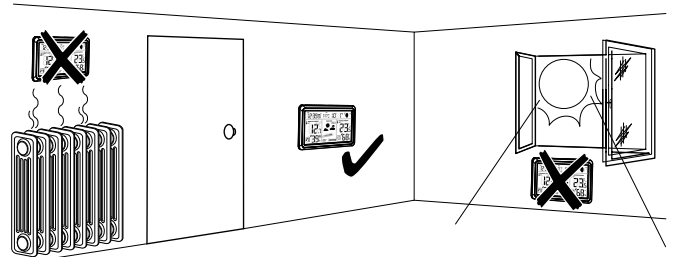

When positioning the outdoor sensor, observe the following:

- Do not expose to direct sunlight.
- Set up protected from direct rain.
- Do not place near door and window openings.
- Do not position horizontally.

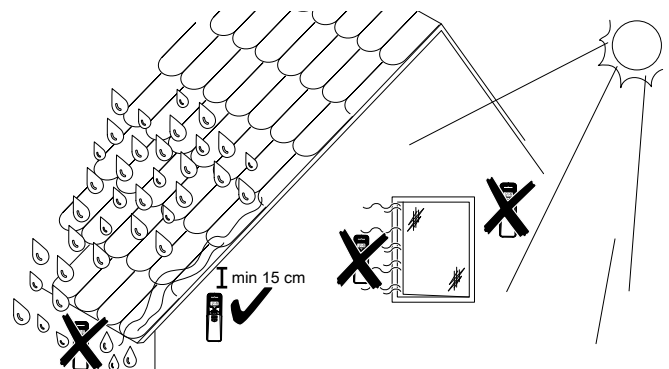

## Tips and notes on the humidity level in living spaces

### General information:

Medical studies of recent years have demonstrated that an increased indoor humidity level of well above 50 to 60 % RH promotes asthma and allergies. A low relative humidity of 30 to 40 %, on the other hand, is harmless. Occasionally, the relative humidity level in flats with a good air exchange can even drop below 30 % during harsh winters without being detrimental to human health.

For the most part, it is the residents themselves who determine the humidity level in their living spaces during the heating period from October to April. A household of 3 to 4 persons emits about ten litres of water vapour into the room air every day, inter alia by taking showers, washing, cooking and breathing. As modern window seals are very tight to save energy costs and provide noise protection, this large amount of humidity must be released to the outside by airing several times a day.

The type of heating and ventilation determines the average relative humidity level in a flat during the winter. Since cold air always has a lower absolute moisture content than normal room air, the humid air can easily be exchanged by fresh, dry air in the winter by repeated brief and intensive airing throughout the day. Every living space that is not equipped with a ventilation system requires air changes several times a day, depending on the occupancy and moisture emission.

A limitation of the relative humidity to prevent too high humidity levels is only required during the heating period starting in autumn. It is recommended to maintain a temperature of approx. 20 °C in the entire flat.

In winter:

In case of average outside temperatures below approx. +5 °C, sufficient air changes and a room temperature of approx. 20 °C, a relative humidity level between 40 and 50 % can easily be obtained. If it exceeds 50 %, the room should be ventilated. During frost periods, an indoor humidity level of less than 40 % RH is perfectly normal. The upper limit of 40 to 50 % RH (at approx. 20 °C) needs to be observed particularly in old buildings with little thermal insulation, as exceeding this value for a prolonged time increases the risk of mould formation.

In autumn or spring:

At milder outside temperatures between 5 and 15 °C on average, the humidity level may reach 50 to 60 % RH.

Please note:

Relatively speaking, warmer rooms are drier and colder rooms get more humid. This is why it is recommended to maintain a room temperature of at least 16 °C.

*Correct airing:*

If your window panes mist up frequently or mould starts to grow on walls, it is high time to review and, if necessary, break your old habits. The answers to the following questions can be useful:

Please note that the hygrometer must not be exposed to hot water or water vapour, otherwise the measurement accuracy can no longer be guaranteed.

## Basic settings

### Temperature unit

1. Press the *WEATHER* button (12) to switch between the units °C and °F.

### Language, date and time zone

1. Press the *MODE* button (8) for 2 seconds to open the language and date settings.
2. Press the *UP* (7) or *DOWN* button (15) to make the respective setting.
3. Press the *MODE* button (8) to confirm the setting and move to the next setting.
  - ⇒ The settings are displayed in the following order: weekday language, time zone, year, month, day, time format, hour, minute, second.
  - ⇒ The weekday and moon phase are adapted automatically when the date has been set.
  - ⇒ If no button has been pressed for 20 seconds, the settings are automatically closed.

### Setting a wake-up time

1. Press the *AL SET* button (10) for 2 seconds to open the alarm clock settings.
  - ⇒ The number of hours flashes and can be set.
2. Press the *UP* (7) or *DOWN* button (15) to make the setting.
3. Press the *AL SET* button (10) briefly to confirm the setting and move to the next setting.
  - ⇒ The number of minutes flashes.
4. Press the *UP* (7) or *DOWN* button (15) to make the setting.
5. Press the *AL SET* button (10) briefly to confirm the setting.



#### Info

You can display the set alarm time by briefly pressing the *AL SET* button (10).

### Switching on the alarm clock



#### Info

The alarm clock is switched off by default.

- ✓ The alarm clock is switched off.
1. Press the *AL ON/OFF* button (13) to switch the alarm clock on.
    - ⇒ The alarm clock is switched on and the *alarm clock* indication (44) is illuminated.
    - ⇒ The alarm clock will ring at the set time.
  2. Press any button except the *SNOOZE* button (6) to switch off the ringing alarm clock.
    - from 0 to 10 seconds: 1 beep per second
    - from 10 to 20 seconds: 2 beeps per second
    - from 20 to 30 seconds: 4 beeps per second
    - from 30 to 120 seconds: continuous beep

### Switching off the alarm clock

- ✓ The alarm clock is switched on.
- 1. Press the *AL ON/OFF* button (13) to switch the alarm clock off.
  - ⇒ The alarm clock is switched off and the *alarm clock* indication (44) is no longer illuminated.

### Illumination and snooze button

The *SNOOZE* button (6) can be used to switch on the snooze function of the alarm clock and the illumination of the display.

The snooze function can be used as follows:

- ✓ The alarm clock rings.
- 1. Press the *SNOOZE* button (6) to activate the snooze function.
  - ⇒ The alarm clock rings again in five minutes.
- 2. Repeat the step as often as desired.
- 3. Press any button except the *SNOOZE* button (6) if you want to switch off the ringing alarm clock.

In mains operation, the illumination can be switched on as follows:

- ✓ The screen is switched off.
- 1. Press the *SNOOZE* button (6) to switch on the illumination.
  - ⇒ The display is illuminated with maximum brightness.
- 2. Press the *SNOOZE* button (6) again to reduce the brightness.
  - ⇒ The display is illuminated with 30 % brightness.
- 3. Press the *SNOOZE* button (6) to switch off the illumination.

In battery operation, the illumination can be switched on as follows:

- ✓ The screen is switched off.
- 1. Press the *SNOOZE* button (6) to switch on the illumination.
  - ⇒ The light is switched on for 10 seconds and then goes out until the button is pressed again.

### Air pressure and weather

- ✓ The device is switched on.
- 1. Press the *WEATHER* button (12) for 2 seconds.
  - ⇒ The unit of the *air pressure* indication (28) flashes.
- 2. Press the *UP* (7) or *DOWN* button (15) to switch between the units hPa and inHg.
- 3. Press the *WEATHER* button (12) to confirm the desired unit.
  - ⇒ The air pressure setting opens and the *air pressure* indication (28) flashes.



#### Info

The value 1012 hPa is set at the factory, which corresponds to the atmospheric pressure at sea level.

- 4. Press the *UP* (7) or *DOWN* button (15) if you want to adjust the air pressure manually.
- 5. Press the *WEATHER* button (12) to confirm the setting.
  - ⇒ The weather setting opens and the *weather forecast* indication (27) flashes.



#### Info

The factory setting is half-sunny. The weather forecast automatically adapts to the measured air pressure trend.

- 6. Press the *UP* (7) or *DOWN* button (15) if you want to adjust the weather setting manually.
- 7. Press the *WEATHER* button (12) to confirm the setting and close the menu.

### Activating the temperature alarm



Item	Display	Meaning
52	<i>Upper alarm limit</i>	Illuminated when an upper limit for the temperature alarm has been set up Flashes when exceeding the upper limit
53	<i>Lower alarm limit</i>	Illuminated when a lower limit for the temperature alarm has been set up Flashes when falling below the lower limit
54	<i>Temperature alarm</i>	Illuminated when the temperature alarm is activated

An alarm can be activated to indicate that the outdoor temperature has exceeded or fallen below a certain level:

- ✓ The alarm is switched off. This is the default factory setting.
- 1. Press the *ALERT* button (14) to activate the alarm.
  - ⇒ The *temperature alarm* indication (54) is illuminated.
  - ⇒ The alarm sounds when the respective target temperature is exceeded or not reached.

**Deactivating the temperature alarm**

- ✓ The alarm is activated.
- 1. Press the *ALERT* button (14) to deactivate the alarm.
  - ⇒ The *temperature alarm* indication (54) disappears.



**Setting the temperature alarm**

- 1. Press the *ALERT* button (14) for 2 seconds.
  - ⇒ The upper limit setting is activated and the temperature indication flashes.
- 2. Press the *UP* (7) or *DOWN* button (15) to set the upper temperature limit.
- 3. Press the *ALERT* button (14) to confirm the setting.
  - ⇒ The *upper alarm limit* indication (52) is illuminated.
  - ⇒ The lower limit setting is activated and the temperature indication flashes.
- 4. Press the *UP* (7) or *DOWN* button (15) to set the lower temperature limit.
- 5. Press the *ALERT* button (14) to confirm the setting.
  - ⇒ The *lower alarm limit* indication (53) is illuminated.
- ⇒ The temperature alarm sounds as soon as the set limit values are exceeded or not reached.

**Reading the display**

**Air pressure trends**

The direction of the arrow indicates the trend of the air pressure (25) as soon as the pressure changes by more than 2 hPa (0.06 inHg) per hour.

Symbol	Meaning
	rising air pressure
	constant air pressure
	falling air pressure

**Air pressure history**

The *air pressure history* indication (26) shows the development of the air pressure within the last 12 hours compared to the currently measured air pressure. "0H" is the currently measured air pressure.

**Daily maximum and minimum values**

- 1. Press the *UP* button (7) to display the daily maximum and minimum values of the air pressure, indoor and outdoor temperature and humidity level indoors and outdoors.
- 2. Press the *UP* button (7) for 2 seconds if you want to delete the daily maximum and minimum values.







**Info**

The values are automatically deleted every day at 0:00 o'clock.



**Comfort indication**

The *comfort* indication (24) indicates whether the combination of measured temperature and humidity provides a comfortable room climate.







Symbol	Meaning	Temperature range	Humidity range
	dry	-	< 40 %
	comfortable	20 – 28 °C	40 – 70 %
	damp	-	> 70 %
	no indication	< 20 or > 28 °C	40 – 70 %

**Weather forecast**

The following symbols show the trend of the indoor temperature (20) and outdoor temperature (32) as well as the indoor humidity level (22) and outdoor humidity level (29).

Symbol	Meaning
	rising temperature or humidity
	constant temperature or humidity
	falling temperature or humidity

The following symbols show the weather forecast for the following 12 hours based on air pressure trends.

Symbol	Meaning	Symbol	Meaning
	sunny		stormy
	partly cloudy		light snowfall
	cloudy		heavy snowfall
	rain		

**Frost warning**

If the outdoor unit measures a temperature between 1 °C (33.8 °F) and -1 °C (30.2 °F), the *frost warning* indication (34) flashes.

If a temperature below -1 °C (30.2 °F) is displayed, the *frost warning* indication (34) will be permanently illuminated.

## Moon phase

The *moon phase* indication (45) displays the current moon phase:

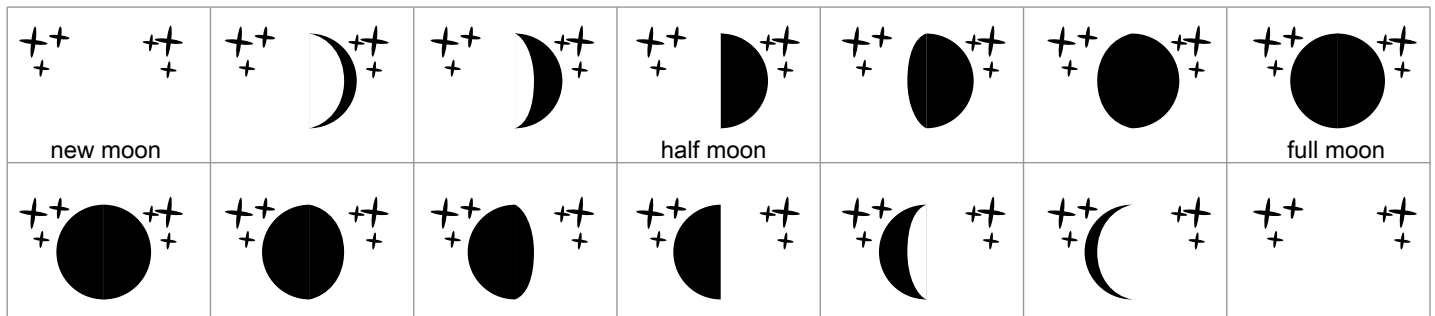

## Errors and faults

Fault description	Cause	Remedy
The display is black.	The display has automatically dimmed during battery operation.	Press the SNOOZE button (6) to switch the illumination back on.
	The illumination has been switched off.	In battery mode, the illumination switches off automatically after 10 seconds.
	The energy supply is not ensured.	Change the batteries or plug in the power adapter.
The measured values are implausible.	The ambient conditions are unrealistic.	Check the positioning of the two units. Mounting the outdoor unit in direct sunlight would, for example, result in higher measuring temperatures being displayed and could damage the unit.
	A restart must be carried out.	<ol style="list-style-type: none"> <li>1. Remove the power adapter and batteries from the main unit.</li> <li>2. Remove the batteries from the outdoor sensor.</li> <li>3. Restore power to the main unit by inserting the batteries and, if necessary, connecting the power adapter.</li> <li>4. Reinsert the batteries into the outdoor sensor.</li> <li>5. Position the units at a distance of a few metres from each other.</li> </ol> <p>⇒ The correct function of the units is restored.</p> <ol style="list-style-type: none"> <li>6. If necessary, make the settings described in the <i>Start-up</i> chapter again.</li> </ol>
The device no longer responds to the push of a button.	A reset must be carried out.	Insert a thin object, e.g. the end of a paper clip, into the reset hole on the back of the unit. The system performs a reset and the factory settings are restored.
The display indication is defective.		

## Maintenance and repair

### Battery change

- A battery change at the display unit is required when the *battery status indoor* indication (18) shows an empty battery.
- A battery change at the outdoor unit is required when the *battery status outdoor* indication (36) on the display unit and the *battery status outdoor unit* indication (49) on the outdoor unit show an empty battery.

Remove the old batteries and insert new ones as described in the Start-up chapter.

### Cleaning

Clean the device with a soft, damp and lint-free cloth. Make sure that no moisture enters the housing. Do not use any sprays, solvents, alcohol-based cleaning agents or abrasive cleaners, but only clean water to moisten the cloth.

### Repair

Do not modify the device or install any spare parts. For repairs or device testing, contact the manufacturer.

## Disposal

Always dispose of packing materials in an environmentally friendly manner and in accordance with the applicable local disposal regulations.



The icon with the crossed-out wheeled bin indicates that this device and any associated components (e.g. remote controls) must not be disposed of with household waste at the end of their life, in accordance with the Waste Electrical and Electronic Equipment Directive (2012/19/EU) and national laws.

You will find collection points for free return of waste electrical and electronic equipment in your vicinity. The addresses can be obtained from your municipality or local administration. You can also find out about other return options that apply for many EU countries on the website <https://hub.trotec.com/?id=45090>. Otherwise, please contact an official recycling centre for electronic and electrical equipment authorised for your country.

The separate collection of waste electrical and electronic equipment aims to enable the re-use, recycling and other forms of recovery of waste equipment as well as to prevent negative effects for the environment and human health caused by the disposal of hazardous substances potentially contained in the equipment.



This icon with the crossed-out wheeled bin indicates that batteries or accumulators must not be disposed of with household waste at the end of their life. If the device contains batteries or accumulators that contain mercury, cadmium or lead, the respective chemical symbol (Hg, Cd or Pb) is shown below the icon of the crossed-out wheeled bin. To prevent environmental pollution, do not carelessly leave batteries or electrical and electronic equipment containing batteries in public areas. In the European Union, batteries and accumulators must be returned to a designated collection point in accordance with REGULATION (EU) 2023/1542 OF THE EUROPEAN PARLIAMENT AND OF THE COUNCIL of 12 July 2023 concerning batteries and waste batteries. Remove batteries/accumulators and dispose of them separately according to the relevant legal requirements.

### Only for United Kingdom

According to Waste Electrical and Electronic Equipment Regulations 2013 (SI 2013/3113) (as amended) and the Waste Batteries and Accumulators Regulations 2009 (SI 2009/890) (as amended), devices that are no longer usable must be collected separately and disposed of in an environmentally friendly manner.

## Declaration of conformity

We – Trotec GmbH – declare in sole responsibility that the product designated below was developed, constructed and produced in compliance with all relevant provisions of the EU Radio Equipment Directive in the version 2014/53/EU.

**Product model / Product:** BZ290S

**Product type:** thermohygrometer

**Year of manufacture as of:** 2023

**The product also complies with all relevant provisions of the following directives/regulations:**

- 2011/65/EU
- 2014/30/EU

**Other EU legal acts applied:**

- 2012/19/EU
- 2014/35/EU

**Applied harmonised standards:**

- EN 300 220-2 V3.1.1

**Applied national standards and technical specifications:**

- EN 301 489-1 V2.2.3:2019-11
- EN 301 489-3 V2.1.1:2017-03
- EN 50663:2017-10
- EN 62368-1:2014/A11:2017-01
- EN 62479:2010
- EN IEC 62368-1:2020/A11:2020

**Manufacturer and name of the authorised representative of the technical documentation:**

Trotec GmbH

Grebener Straße 7, D-52525 Heinsberg

Phone: +49 2452 962-0

E-mail: [online@trotec.com](mailto:online@trotec.com)

Place and date of issue:

Heinsberg, 02.02.2023



Joachim Ludwig, Managing Director

Trotec GmbH

Grebber Str. 7  
52525 Heinsberg  
Germany

☎ +49 2452 962-0

☎ +49 2452 962-200

[online@trotec.com](mailto:online@trotec.com)

[www.trotec.com](http://www.trotec.com)