

# EN

**INSTRUCTIONS**  
LASER DISTANCE MEASURING  
DEVICE



**Table of contents**

**Information on the use of these instructions** ..... 2

**Safety** ..... 2

**Information about the device** ..... 4

**Transport and storage** ..... 7

**Operation** ..... 7

**Maintenance and repair** ..... 12

**Errors and faults** ..... 12

**Disposal** ..... 13

**Information on the use of these instructions**

**Symbols**

 **Warning of electrical voltage**  
This symbol indicates dangers to the life and health of persons due to electrical voltage.

 **Warning of laser radiation**  
This symbol indicates dangers to the health of persons due to laser radiation.

 **Warning**  
This signal word indicates a hazard with an average risk level which, if not avoided, can result in serious injury or death.

 **Caution**  
This signal word indicates a hazard with a low risk level which, if not avoided, can result in minor or moderate injury.

**Notice**  
This signal word indicates important information (e.g. material damage), but does not indicate hazards.

 **Info**  
Information marked with this symbol helps you to carry out your tasks quickly and safely.

 **Follow the manual**  
Information marked with this symbol indicates that the instructions must be observed.

You can download the current version of the instructions and the EU declaration of conformity via the following link:



BD8M



<https://hub.trotec.com/?id=45779>

**Safety**

**Read this manual carefully before starting or using the device. Always store the manual in the immediate vicinity of the device or its site of use.**

-  **Warning**  
**Read all safety warnings and all instructions.** Failure to follow the warnings and instructions may result in electric shock, fire and/or serious injury.  
**Save all warnings and instructions for future reference.**
- Do not use the device in potentially explosive rooms or areas and do not install it there.
  - Do not use the device in an aggressive atmosphere.
  - Do not immerse the device in water. Do not allow liquids to penetrate into the device.
  - The device may only be used in dry surroundings and must not be used in the rain or at a relative humidity exceeding the operating conditions.
  - Protect the device from permanent direct sunlight.
  - Do not open the device.
  - Do not remove any safety signs, stickers or labels from the device. Keep all safety signs, stickers and labels in legible condition.
  - Avoid looking directly into the laser beam.
  - Never point the laser beam at people or animals.
  - Use batteries of type AAA.
  - Never charge batteries that cannot be recharged.
  - Different types of batteries and new and used batteries must not be used together.
  - Insert the batteries into the battery compartment according to the correct polarity.
  - Remove discharged batteries. Batteries contain materials hazardous to the environment. Dispose of the batteries according to the national regulations.
  - Remove the batteries from the device if you will not be using the device for a longer period of time.

- Never short-circuit the supply terminal in the battery compartment!
- Do not swallow batteries! If a battery is swallowed, it can cause severe internal burns within 2 hours! These burns can lead to death!
- If you think batteries might have been swallowed or otherwise entered the body, seek medical attention immediately!
- Keep new and used batteries and an open battery compartment away from children.
- Only use the device, if sufficient safety precautions were taken at the surveyed location (e.g. when performing measurements along public roads, on building sites etc.). Otherwise do not use the device.
- Observe the storage and operating conditions (see Technical data).

### Intended use

Only use the device for measuring distances, areas and volumes by means of the integrated laser and within the measuring range specified in the technical data. Only use the integrated cross line laser for the projection on non-reflective surfaces as an aid to determine and check horizontal, vertical and / or parallel lines. Observe and comply with the technical data.

Any use other than the intended use is regarded as misuse.

### Reasonably foreseeable misuse

Do not use the device in potentially explosive atmospheres, or for measurements in liquids.

Never point it at people or animals.

Any unauthorised modifications, alterations or structural changes to the device are forbidden.

### Personnel qualification

People who use this device must:



- be aware of the dangers that occur when working with laser measuring devices.
- have read and understood the instructions, especially the Safety chapter.

### Safety signs and labels on the device

#### Notice

Do not remove any safety signs, stickers or labels from the device. Keep all safety signs, stickers and labels in legible condition.

The following safety signs and labels are attached to the device:

Safety symbol	Meaning
	<p>The warning sign is located on the side of the device next to the belt clip and indicates that the device is equipped with a class 2 laser.</p> <p>The power is less than 1 mW. The frequency range of the laser is 630 to 670 nm.</p> <p><b>Do not look directly into the laser beam or the opening from which the laser beam emerges!</b></p>
	<p>The warning sign is located on the side of the device next to the buttons.</p> <p><b>Do not look directly into the laser beam or the opening from which the laser beam emerges!</b></p>

## Residual risks



### Warning of electrical voltage

There is a risk of a short-circuit due to liquids penetrating the housing!  
Do not immerse the device and the accessories in water. Make sure that no water or other liquids can enter the housing.



### Warning of electrical voltage

Work on the electrical components must only be carried out by an authorised specialist company!



### Warning of laser radiation



**Laser class 2, P max.: < 1 mW, λ: 400-700 nm, EN 60825-1:2014**

Do not look directly into the laser beam or the opening from which it emerges.

Never point the laser beam at people, animals or reflective surfaces. Even brief eye contact can lead to eye damage.

Examining the laser output aperture by use of optical instruments (e.g. magnifying glass, magnifiers and the like) entails the risk of eye damage.

When working with a laser of class 2, observe the national regulations on wearing eye protection.



### Warning

Risk of suffocation!  
Do not leave the packaging lying around. Children may use it as a dangerous toy.



### Warning

The device is not a toy and does not belong in the hands of children.



### Warning

Dangers can occur at the device when it is used by untrained people in an unprofessional or improper way!  
Observe the personnel qualifications!



### Caution

Keep a sufficient distance from heat sources.

### Notice

To prevent damages to the device, do not expose it to extreme temperatures, extreme humidity or moisture.

### Notice

Do not use abrasive cleaners or solvents to clean the device.

## Information about the device

### Device description

The laser distance measuring device BD8M is used to determine distances, areas and volumes. Indirect measurements are carried out employing the Pythagoras function.

The device is equipped with an integrated cross line laser and a tape measure for measurements up to 5 m.

The device is equipped with separate operating elements for the different measuring functions. The multi-line, backlit display indicates the determined values and measuring functions.

### Measuring distance

The range of the device can be gathered from the Technical data chapter. Under certain conditions – e.g. at night, in twilight or when the target is hidden in the shade – greater distances are possible even without target plate. During the day use a target plate to increase the distance for poorly reflecting targets.

### Target surfaces

There might be measurement errors when the laser encounters colourless liquids (e.g. water), dust-free glass, styrofoam or other semi-permeable materials. The measurement result may also be falsified if the laser encounters a high-gloss surface and is deflected by it. Non-glossy, non-reflective or dark surfaces can extend the measurement duration.

## Device depiction

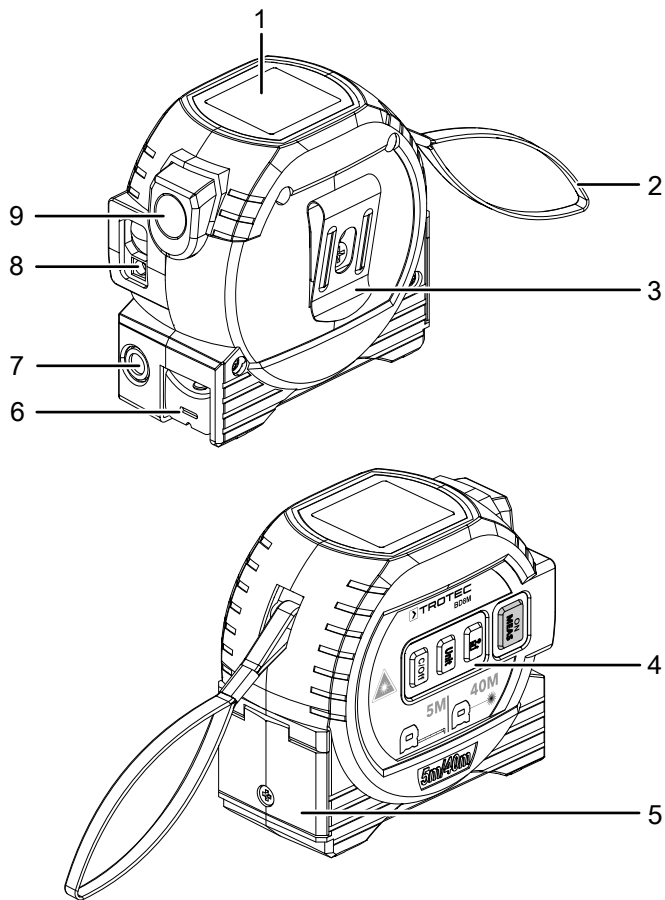

## Operating elements

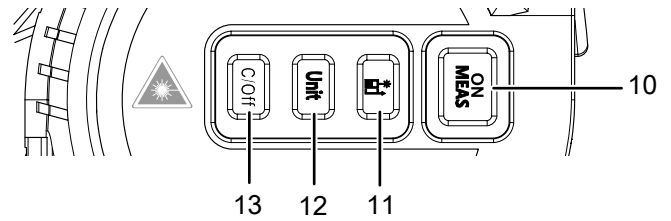

No.	Designation	Function
10	<i>ON/MEAS</i> button	Press briefly: switching the device on/measuring
		Press and hold: starting continuous distance measurement
		Press for 5 s: switching the cross line laser on
11	* button	Press briefly: changing the measuring functions
		Press and hold: change the reference point
12	<i>Unit</i> button	Press briefly: requesting stored values
		Press and hold: changing between the units / clearing the history
13	<i>C/Off</i> button	Press briefly: deleting last value
		Press and hold: Switching the device off

No.	Designation
1	Display
2	Wrist strap
3	Belt clip
4	Operating elements
5	Battery compartment with cover
6	Tape measure
7	Cross line laser
8	Laser
9	Return button

**Display**

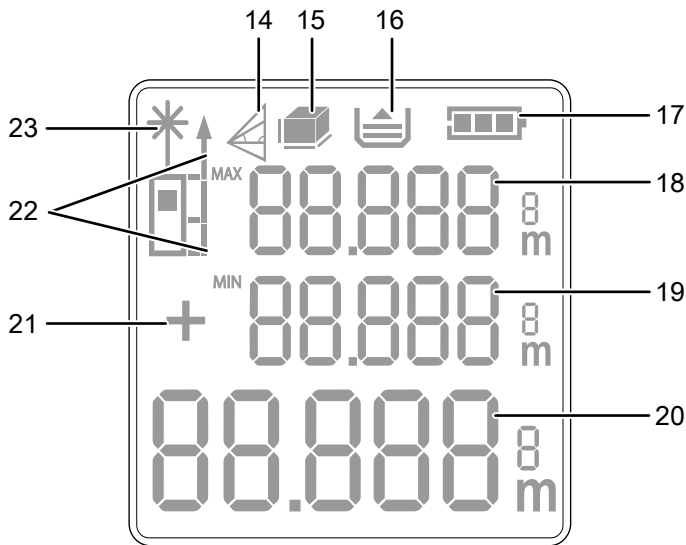

No.	Indication	Function
14	<i>Indirect measurement</i>	<ul style="list-style-type: none"> <li>Indirect measurement (two auxiliary measurements)</li> <li>Indirect measurement (three auxiliary measurements)</li> </ul>
15	<i>Space</i>	<ul style="list-style-type: none"> <li>Area measurement</li> <li>Volume measurement</li> </ul>
16	<i>History</i>	history of measured values opened
17	<i>Battery status</i>	indicates the battery charge level
18	<i>Measured value 1</i>	first measured value/maximum value
19	<i>Measured value 2</i>	second or third measured value/minimum value
20	<i>Lower measured value display</i>	last measured value/result of a calculation
21	<i>+/-</i>	Addition/subtraction of measured values
22	<i>Reference point</i>	<ul style="list-style-type: none"> <li>Front reference point</li> <li>Rear reference point</li> </ul>
23	<i>Laser</i>	Laser active

**Technical data**

Parameter	Value
Model	BD8M
Weight	295 g
Dimensions (H x W x D)	85 x 82 x 56 mm
Measuring range of tape measure	0 to 5 m
Measuring range of laser	0.20 to 40 m 0.66 to 131 ft
Measuring units	m/ft/in/ft+in
Accuracy	± 2 mm
Measuring range resolution	1 mm
Range of cross line laser	10 m
Number of recordings logged in the history	20
Operating temperature	0 °C to 40 °C (32 °F to 104 °F)
Storage temperature	-10 °C to 60 °C (14 °F to 140 °F)
Laser output	< 1 mW (650 nm)
Laser class	II
Device switch-off	After approx. 2 minutes of non-use
Laser/display illumination	After approx. 30 seconds of switch-off
Power supply	2 x 1.5 V battery (type AAA)

**Scope of delivery**

- 1 x Device BD8M (without batteries)
- 1 x Quick guide

## Transport and storage

### Notice

If you store or transport the device improperly, the device may be damaged.

Note the information regarding transport and storage of the device.

### Transport

When transporting the device, ensure dry conditions and protect the device from external influences e.g. by using a suitable bag.

### Storage

When the device is not being used, observe the following storage conditions:

- dry and protected from frost and heat
- protected from dust and direct sunlight
- at the temperature specified in the technical data
- Batteries are removed from the device

## Operation

### Inserting the batteries

#### Notice

Make sure that the surface of the device is dry and the device is switched off.

1. Loosen the cover of the battery compartment (5) with a screwdriver.
2. Insert two batteries of type AAA (1.5 V) into the battery compartment with correct polarity (+/-).

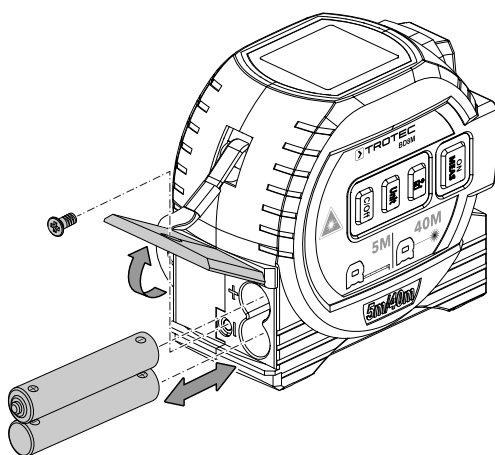

3. Put the cover of the battery compartment back onto the device and tighten it with the screws.

### Switch-on

1. Press the *ON/MEAS* button (10) for approx. 1 second.
  - ⇒ The display will be switched on and the device ready for operation.

### Basic settings

#### Adjusting the reference point

The device always measures the total distance starting at the reference point. This means that if the rear end of the device is set as reference point, the length of the device will be part of the measurement. By default the reference point is set to the rear of the device. You can, however, also relocate the reference point to the front part of the device. To do so, please proceed as follows:

1. Press the  button (11) for a long time to relocate the reference point to the front end of the device.
  - ⇒ An acoustic signal is emitted when the reference point is relocated.
  - ⇒ The *reference point* display (22) indicates the selected reference point.

When switching the device off and then on again, the reference point will automatically be relocated to the rear end of the device.

#### Changing the units

1. Press and hold the *Unit* button (12) several times to switch between the units for the measured values. The unit is displayed behind the three measured value displays (18, 19, 20). You can set the following units one after the other:
  - ⇒ 0.000 m (indication in metres, accuracy 1 mm)
  - ⇒ 0.0 in (indication in inches, accuracy 1/10 inch)
  - ⇒ 0 in (indication in inches, accuracy 1 inch)
  - ⇒ 0.00 ft (indication in feet, accuracy 1/10 ft)
  - ⇒ 0' 0" (indication in feet and 1/8 inch, accuracy 1/8 inch)

#### Calling up a measured value in the device history

The device automatically saves the last 20 measured values.

The saved measured values can be called up as follows:

1. Briefly press the *Unit* button (12) to call up the history.
  - ⇒ The History indication (16) appears.
  - ⇒ The *Measured value 1* display (18) indicates the value of the selected measurement.
2. Briefly press the *Unit* button (12) again to navigate through the history and call up the saved measured values.
3. Press the *Unit* button (12) for a long time to delete the saved measured values.
4. Briefly press the *C/Off* button (13) to open the main menu.

**Carrying out measurements**



**Warning of laser radiation**

**Laser class 2, P max.: < 1 mW, λ: 400-700 nm, EN 60825-1:2014**

Do not look directly into the laser beam or the opening from which it emerges.

Never point the laser beam at people, animals or reflective surfaces. Even brief eye contact can lead to eye damage.

Examining the laser output aperture by use of optical instruments (e.g. magnifying glass, magnifiers and the like) entails the risk of eye damage.

When working with a laser of class 2, observe the national regulations on wearing eye protection.



**Info**

Before carrying out measurements, make sure that the correct reference point is selected. By default, the rear reference point is selected. The reference point should not be changed in the course of a measurement!

**Notice**

You can cancel an ongoing measurement at any time by pressing the *C/Off* button (13).

**Notice**

For measurements with several measured values, you can delete the measured values step by step by pressing the *C/Off* button (13).

1. Press the  button (11) several times to call up the following measuring modes one after the other:
  - ⇒ Single distance measurement:
    - you can add or subtract measured values
    - you can perform a non-stop measurement with MAX/MIN/current value
  - ⇒ Area measurement
  - ⇒ Volume measurement
  - ⇒ Indirect height measurement
  - ⇒ Twofold indirect height measurement

**Performing a single distance measurement**

1. Briefly press the *ON/MEAS* button (10) to activate the laser.
  - ⇒ The *Laser* indication (23) flashes when the laser is active.
2. Point the laser at the target area.
3. Briefly press the *ON/MEAS* button (10) again to perform a distance measurement.
  - ⇒ The *Laser* indication (23) goes out during the measurement.
  - ⇒ The measured value is shown in the *Lower measurement value display* (20).

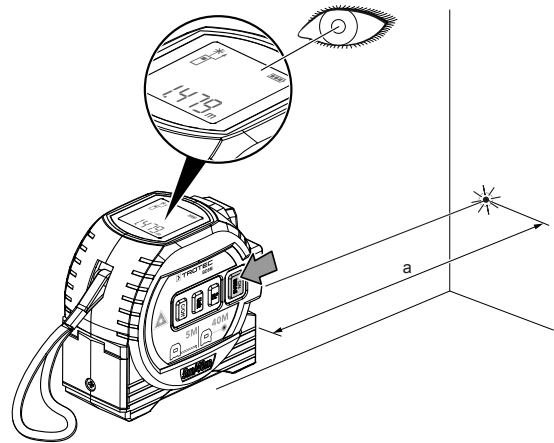

**Info**

The laser is automatically switched off after approx. 30 seconds when not in use. Briefly press the *ON/MEAS* button (10) to switch the laser on again.



## Performing a continuous, MIN or MAX measurement

With this measurement method the device can be moved with the measured value being recalculated roughly every 0.5 seconds. You can use the non-stop measurement function with MAX/MIN/current value display for performing the following measurements, for example:

- measuring a diagonal (MAX value)

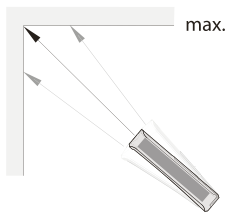

- determining the perpendicular length to a wall/floor area (MIN value)

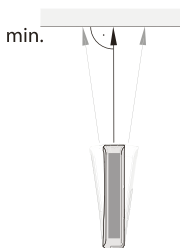

- marking a defined value for a distance (e.g. a measurement from a ground plan)

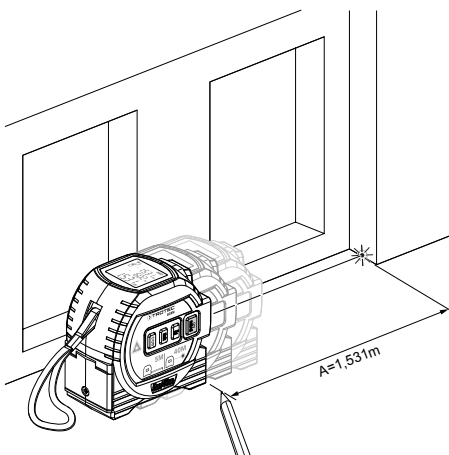

- Press the *ON/MEAS* button (10) for approx. 3 seconds.
  - ⇒ A recurring acoustic signal is emitted.
  - ⇒ The *Laser* indication (23) is illuminated.
  - ⇒ Next to the indication of *Measured value 1* (18), the MAX symbol flashes, and next to the indication of *Measured value 2* (19), the MIN symbol flashes.

- Depending on the desired measurement, move the device slowly back and forth or up and down (e.g. in the corner of a room).
  - ⇒ The maximum value (18), minimum value (19) and current value (20) are indicated on the display.
- Briefly press the *ON/MEAS* button (10) to terminate the continuous measurement.
  - ⇒ The maximum value (18), minimum value (19) and last value (20) are indicated on the display.

## Adding / subtracting measured values



- Briefly press the button (11) once to add two measured values.
  - Briefly press the button (11) twice to subtract two measured values.
- Briefly press the *ON/MEAS* button (10) to perform a measurement.
  - ⇒ The measured value is shown in the *Measured value 1* display (18).
- Briefly press the *ON/MEAS* button (10) again to perform the second measurement.
  - ⇒ The second measured value is shown in the *Measured value 2* display (19).
  - ⇒ The overall result is shown in the *Lower measured value display* (20).

## Performing an area measurement

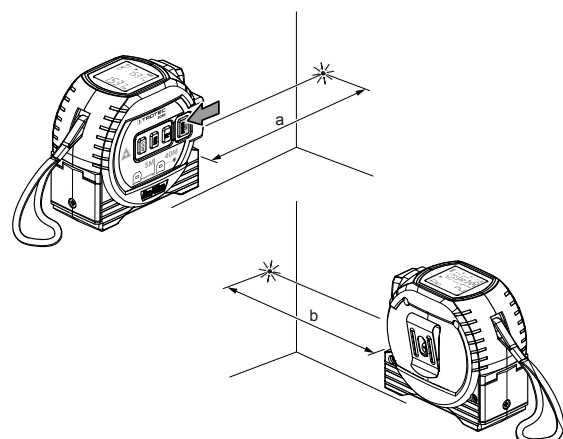
- Repeatedly press the button (11) until the symbol for the area measurement appears in the *Space* indication (15).
- Briefly press the *ON/MEAS* button (10) to carry out the first measurement (e.g. length).
  - ⇒ The measured value is shown in the *Measured value 1* display (18).
- Briefly press the *ON/MEAS* button (10) again to carry out the second measurement (e.g. width).
  - ⇒ The second measured value is shown in the *Measured value 2* display (19).
  - ⇒ Upon pressing the *ON/MEAS* button (10) for the second time, the device independently calculates the area and shows this value in the *Lower measured value display* (20).



**Performing a volume measurement**

1. Repeatedly press the  button (11) until the  symbol for the volume measurement appears in the *Space* indication (15).
    - ⇒ The side to be measured is displayed flashing.
  2. Briefly press the *ON/MEAS* button (10) to carry out the first measurement (e.g. length).
    - ⇒ The length of the line segment is shown in the *Measured value 1* display (18).
  3. Briefly press the *ON/MEAS* button (10) again to carry out the second measurement (e.g. width).
    - ⇒ The second measured value is shown in the *Measured value 2* display (19).
    - ⇒ The area value is indicated as an intermediate result in the *Lower measured value display* (20).
  4. Briefly press the *ON/MEAS* button (10) again to carry out the third measurement (e.g. height).
    - ⇒ The third measured value is shown in the *Measured value 2* display (19).
- ⇒ Upon pressing the *ON/MEAS* button (10) for the third time, the device independently calculates the volume and shows this value in the *Lower measured value display* (20).

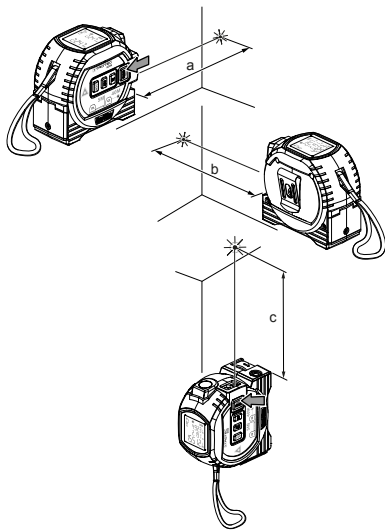



**Indirect height measurement (Pythagoras)**

Using this method the length of an unknown distance (a) can be determined via the Pythagorean theorem. This method is suitable for e.g. height measurements.

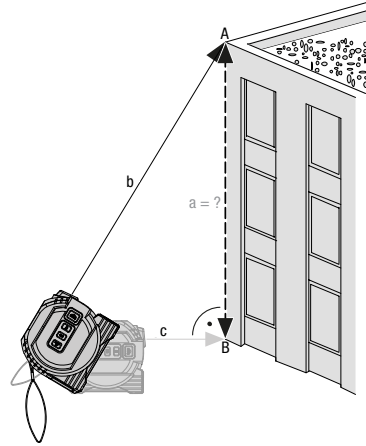
The measurement result (a) is calculated by determining the distances b and c.



✓ The lines a and c meet at right angles.

1. Repeatedly press the  button (11) until the  symbol appears in the *Indirect measurement* display (14).
  - ⇒ The upper bar (hypotenuse) flashes.
2. First, aim the device at the highest point (A) and briefly press the *ON/MEAS* button (10) once to perform a measurement. Make sure to hold the device as steady as possible and place it level on the ground with the two rear edges. **The position at the two rear edges must not be changed during the measurements!**
  - ⇒ The length of the line segment is shown in the *Measured value 1* display (18).
3. Align the device horizontally at the lower measuring point (B) and briefly press the *ON/MEAS* button (10) once to measure the horizontal distance.
  - ⇒ The second measured value is shown in the *Measured value 2* display (19).
  - ⇒ The line segment to be determined is shown as result in the *Lower measured value display* (20).

## Twofold indirect height measurement

This method is suitable for e.g. height measurements when you are not at the same height as the base point.

The measurement result (a) is calculated by determining the distances b, c and d.

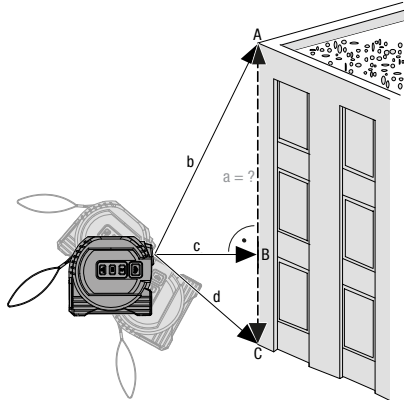

✓ The lines a and c meet at right angles.

1. Repeatedly press the button (11) until the symbol for the twofold indirect measurement appears in the *Indirect measurement* display (14).
2. First, aim the device at the highest point (A) and briefly press the *ON/MEAS* button (10) once to perform a measurement. In doing so, hold the device as steady as possible. **The alignment of the device in relation to the reference point must not be changed during the measurements!**
  - ⇒ The length of the line segment is shown in the *Measured value 1* display (18).
3. Align the device horizontally (to measuring point (B)) and briefly press the *ON/MEAS* button (10) once to measure the horizontal distance.
  - ⇒ The second measured value is shown in the *Measured value 2* display (19).
4. Aim the device at the deepest point (C) and briefly press the *ON/MEAS* button (10) once to perform a measurement.
  - ⇒ The third measured value is shown in the *Measured value 2* display (19).
  - ⇒ The line segment to be determined is shown as result in the *Lower measured value display* (20).

## Using the cross line laser

The cross line laser projects laser lines on surfaces, e.g. to drill holes in a straight line – similar to using a spirit level.

You can switch to the cross line laser from any measurement function.

Before using the crossline laser, place the device in a horizontal position, e.g. on a spirit level.

1. Press the *ON/MEAS* button (10) for approx. 5 seconds.
  - ⇒ An acoustic signal is emitted.
  - ⇒ The laser is displayed on the target area as a right-angled cross.
2. Briefly press the *ON/MEAS* button (10) to switch to the point laser.

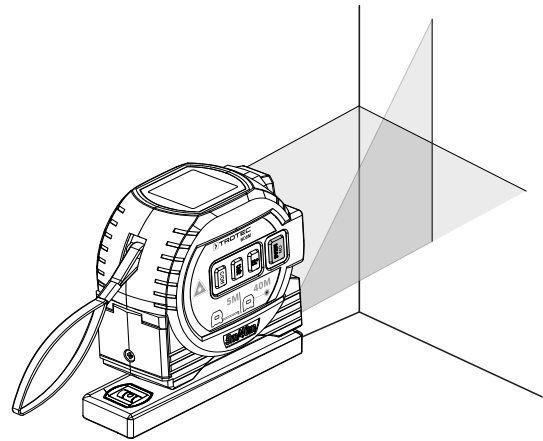

The laser is displayed as a point by default when the device is switched on again.

## Using the tape measure

You can manually measure distances of up to 5 m/40 ft using the integrated tape measure.

1. Pull out the tape measure (6) and hold the metal end piece at the target point of the desired measurement.
  - ⇒ The tape measure is blocked once the length is pulled out.
2. Read the measured distance from the scale on the tape measure.
  - ⇒ The tape measure indicates the distance in 0.000 m (lower scale) and in 0.0 ft (upper scale).
3. Press and hold the return button (9) to roll up the tape measure again.
  - ⇒ The tape measure is automatically retracted into the device.

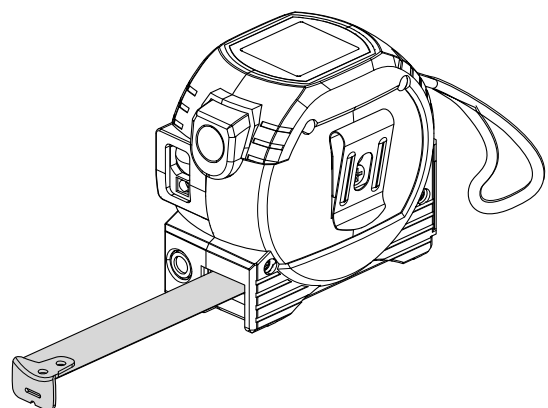

### Switch-off

1. Press the *C/Off* button (13) for a long time.
  - ⇒ The display is switched off.
  - ⇒ An acoustic signal is emitted.

The device automatically switches off after approx. 2 minutes of non-use.

## Maintenance and repair

### Battery change

A battery change is required when the *Battery status* indication (17) flashes on the display or when the device can no longer be switched on (see chapter Inserting the batteries).

### Cleaning

Clean the device with a soft, damp and lint-free cloth. Make sure that no moisture enters the housing. Do not use any sprays, solvents, alcohol-based cleaning agents or abrasive cleaners, but only clean water to moisten the cloth.

### Repair

Do not modify the device or install any spare parts. For repairs or device testing, contact the manufacturer.

## Errors and faults

The device has been checked for proper functioning several times during production. If malfunctions occur nonetheless, check the device according to the following list.

### The device does not switch on:

- Check the charging status of the batteries. Change the batteries, if required.
- Check that the batteries are properly positioned. Check the polarity is correct.
- Never carry out an electrical check yourself; instead, contact the manufacturer's customer service.

### Display segments are only faintly visible or flicker:

- The battery voltage is too low. Exchange the batteries immediately.
- Check that the batteries are properly positioned. Check the polarity is correct.

### The device displays implausible measured values.

- The battery voltage is too low. Exchange the batteries immediately.
- Check that the batteries are properly positioned. Check the polarity is correct.

The following fault indications can appear in the measurement value display (20):

Display	Cause	Remedy
203	The temperature is too high.	Allow the device to cool down. Observe the permissible operating temperature according to the Technical data chapter.
220	The batteries are almost empty.	Change the batteries, see section Battery change.
254	Calculation error	Repeat the measurement. Pay attention to the measurement sequence and position of the device.
255	The reception of the reflected signal is too weak.	Repeat measurement on another surface with better reflective properties or use a target plate.
256	The reception of the reflected signal is too strong.	
258	Range exceeded	Observe the range values specified in the Technical data chapter.
301	Hardware fault	Repeatedly switch the device on and off. If the indication continues to appear, please contact the Trotec customer service.

## Disposal

Always dispose of packing materials in an environmentally friendly manner and in accordance with the applicable local disposal regulations.



The icon with the crossed-out waste bin on waste electrical or electronic equipment is taken from Directive 2012/19/EU. It states that this device must not be disposed of with the household waste at the end of its life. You will find collection points for free return of waste electrical and electronic equipment in your vicinity. The addresses can be obtained from your municipality or local administration. You can also find out about other return options that apply for many EU countries on the website <https://hub.trotec.com/?id=45090>. Otherwise, please contact an official recycling centre for electronic and electrical equipment authorised for your country.

The separate collection of waste electrical and electronic equipment aims to enable the re-use, recycling and other forms of recovery of waste equipment as well as to prevent negative effects for the environment and human health caused by the disposal of hazardous substances potentially contained in the equipment.



In the European Union, batteries and accumulators must not be treated as domestic waste, but must be disposed of professionally in accordance with Directive 2006/66/EC of the European Parliament and of the Council of 6 September 2006 on batteries and accumulators. Please dispose of batteries and accumulators according to the relevant legal requirements.

### Only for United Kingdom

According to Waste Electrical and Electronic Equipment Regulations 2013 (SI 2013/3113) (as amended) and the Waste Batteries and Accumulators Regulations 2009 (SI 2009/890) (as amended), devices that are no longer usable must be collected separately and disposed of in an environmentally friendly manner.

Trotec GmbH

Grebener Str. 7  
D-52525 Heinsberg

☎ +49 2452 962-400

☎ +49 2452 962-200

✉ [info@trotec.com](mailto:info@trotec.com)

[www.trotec.com](http://www.trotec.com)