

EN

ORIGINAL INSTRUCTIONS
DIGITAL SOUND LEVEL METER



TROTEC
BS06

Table of contents

Notes regarding the instructions 2

Safety 2

Information about the device 4

Transport and storage 5

Operation 5

Errors and faults 6

Maintenance and repair 6

Disposal 6

Notes regarding the instructions

Symbols



Warning of electrical voltage

This symbol indicates dangers to the life and health of persons due to electrical voltage.



Warning

This signal word indicates a hazard with an average risk level which, if not avoided, can result in serious injury or death.



Caution

This signal word indicates a hazard with a low risk level which, if not avoided, can result in minor or moderate injury.

Note

This signal word indicates important information (e.g. material damage), but does not indicate hazards.



Info

Information marked with this symbol helps you to carry out your tasks quickly and safely.



Follow the manual

Information marked with this symbol indicates that the instructions must be observed.

You can download the current version of the instructions and the EU declaration of conformity via the following link:



BS06



<https://hub.trotec.com/?id=43270>

Safety

Read this manual carefully before starting or using the device. Always store the manual in the immediate vicinity of the device or its site of use.



Warning

Read all safety warnings and all instructions.

Failure to follow the warnings and instructions may result in electric shock, fire and/or serious injury.

Save all warnings and instructions for future reference.

- Do not use the device in potentially explosive rooms or areas and do not install it there.
- Do not use the device in aggressive atmosphere.
- Do not immerse the device in water. Do not allow liquids to penetrate into the device.
- The device may only be used in dry surroundings and must not be used in the rain or at a relative humidity exceeding the operating conditions.
- Protect the device from permanent direct sunlight.
- Do not expose the device to strong vibrations.
- Do not remove any safety signs, stickers or labels from the device. Keep all safety signs, stickers and labels in legible condition.
- Do not open the device.
- Never charge batteries that cannot be recharged.
- Different types of batteries and new and used batteries must not be used together.
- Insert the batteries into the battery compartment according to the correct polarity.
- Remove discharged batteries from the device. Batteries contain materials hazardous to the environment. Dispose of the batteries according to the national regulations.
- Remove the batteries from the device if you will not be using the device for a longer period of time.
- Never short-circuit the supply terminal in the battery compartment!
- Do not swallow batteries! If a battery is swallowed, it can cause severe internal burns within 2 hours! These burns can lead to death!
- If you think batteries might have been swallowed or otherwise entered the body, seek medical attention immediately!
- Keep new and used batteries and an open battery compartment away from children.
- Only use the device, if sufficient safety precautions were taken at the surveyed location (e.g. when performing measurements along public roads, on building sites etc.). Otherwise do not use the device.

- Observe the storage and operating conditions (see Technical data).
- Do not expose the device to directly squirting water.
- Check accessories and connection parts for possible damage prior to every use of the device. Do not use any defective devices or device parts.

Intended use

Only use the device for sound level measurements within the measuring range specified in the technical data.

To use the device for its intended use, only use accessories and spare parts which have been approved by Trotec.

Foreseeable misuse

Do not use the device in potentially explosive atmospheres, for measurements in liquids and at live parts. In such a case, any warranty claims will be voided. Any unauthorised modifications, alterations or structural changes to the device are forbidden.

Personnel qualifications

People who use this device must:

- have read and understood the instructions, especially the Safety chapter.

Personal protective equipment



Wear hearing protection

Wear hearing protection when handling the device.

Residual risks



Warning of electrical voltage

There is a risk of a short-circuit due to liquids penetrating the housing!

Do not immerse the device and the accessories in water. Make sure that no water or other liquids can enter the housing.



Warning of electrical voltage

Work on the electrical components must only be carried out by an authorised specialist company!



Warning

Risk of hearing damage!

Ensure sufficient ear protection when there are sources of loud sound. There is a danger of hearing damage.



Warning

Risk of suffocation!

Do not leave the packaging lying around. Children may use it as a dangerous toy.



Warning

The device is not a toy and does not belong in the hands of children.



Warning

Dangers can occur at the device when it is used by untrained people in an unprofessional or improper way! Observe the personnel qualifications!



Caution

Keep a sufficient distance from heat sources.

Note

To prevent damages to the device, do not expose it to extreme temperatures, extreme humidity or moisture.

Note

Do not use abrasive cleaners or solvents to clean the device.

Information about the device

Device description

By use of the digital sound level meter BS06 the sound level can be measured in dB(A) in real time.

A MAX/MIN function is available for the assessment of the measurements.

The display illumination automatically adjusts to the ambient light conditions.

When not in use, an automatic switch-off saves the battery.

Device depiction

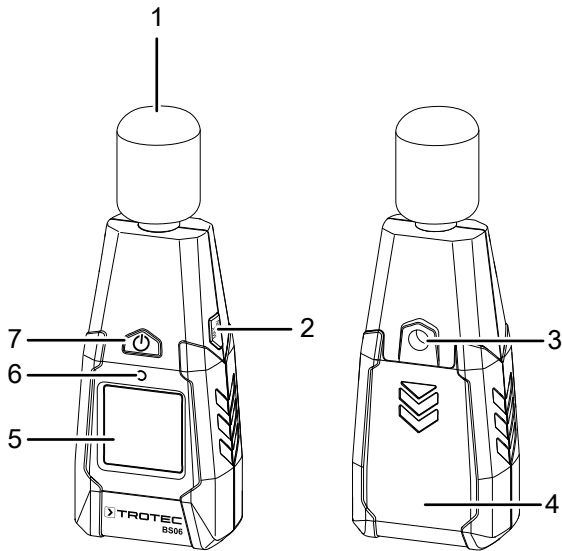

No.	Designation
1	Microphone with wind shield
2	MAX/MIN button
3	Tripod thread
4	Battery compartment with cover
5	Display
6	Light sensor
7	Power button

Display

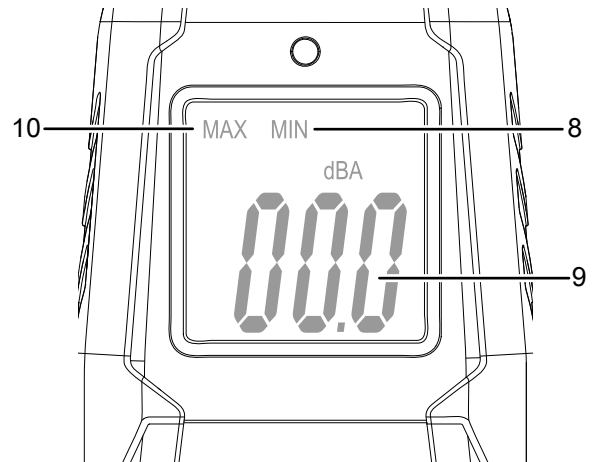

No.	Designation
8	Minimum value indication
9	Indication of the measured value in dB(A)
10	Maximum value indication

Technical data

Parameter	Value
Model	BS06
Weight	140 g
Dimensions (length x width x height)	132 mm x 56 mm x 33 mm
Measuring range	30 to 130 dB(A) (31.5 Hz to 8 kHz)
Accuracy	± 3.5 dB (at 1 kHz and 94 dB)
Measuring range resolution	0.1 dB
Time weighting	125 ms
Microphone	1/2-inch electret condenser microphone
Operating temperature	0 to 40 °C with 10 to 75 % RH
Operating altitude	max. 2000 m
Storage temperature	-10 to 60 °C
Power supply	1 x Alkaline 9 V battery battery life: approx. 5000 to 8000 measurements
Automatic switch-off	after approx. 15 minutes

Scope of delivery

- 1 x Digital sound level meter BS06
- 1 x Bag
- 1 x 9 V battery
- 1 x Wind shield for microphone
- 1 x manual

Transport and storage

Note

If you store or transport the device improperly, the device may be damaged.

Note the information regarding transport and storage of the device.

Transport

For transporting the device, use the bag included in the scope of delivery in order to protect the device from external influences.

Storage

When the device is not being used, observe the following storage conditions:

- dry and protected from frost and heat
- protected from dust and direct sunlight
- with a cover to protect it from invasive dust if necessary
- the storage temperature complies with the values specified in the Technical data
- Remove the batteries from the device.

Operation

Inserting the battery

Note

Make sure that the surface of the device is dry and the device is switched off.

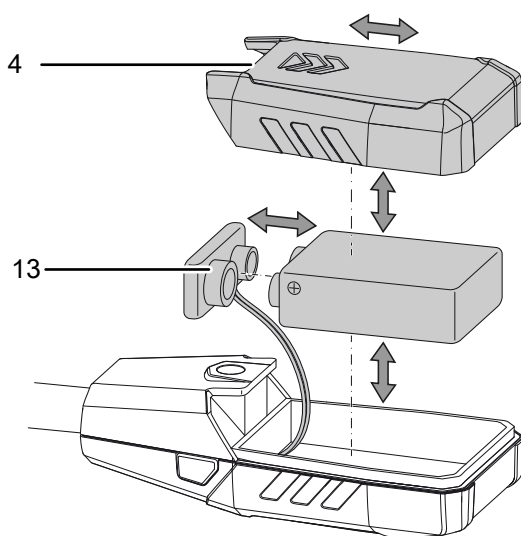

1. Remove the cover (4) from the device by sliding it in the direction of the arrow.
2. Use the battery clip (13) to connect the new battery with correct polarity.
3. Slide the cover (4) back on the device.

Switch-on and measurements

1. Press the power button (7).
 - ⇒ The display will be switched on and the device ready for operation.
 - ⇒ In case of poor lighting conditions the display illumination switches on automatically. The display illumination is controlled by the sensor (6).
2. Point the device with the microphone end directly toward the sound source.
 - ⇒ Reach out as far as possible to hold the device away from your body or mount it to a tripod via the tripod thread (3). This helps to avoid foreign influences during the sound measurement.
 - ⇒ If it is windy (> 10 m/s) use the supplied wind shield so as not to falsify the measured value.
 - ⇒ The measured value will be displayed in dB(A).

Note

Note that moving from a cold area to a warm area can lead to condensation forming on the device's circuit board. This physical and unavoidable effect can falsify the measurement. In this case, the display shows either no measured values or they are incorrect. Wait a few minutes until the device has become adjusted to the changed conditions before carrying out a measurement.



Info

Please note that the measurement of a sound source always has to be carried out directly. There must be no objects or persons located in between the microphone and the sound source, unless their influence on the sound intensity is to be measured on purpose as well.

Setting the MAX / MIN function

By use of the MAX/MIN function you can either read the highest or the lowest value.

1. Press the MAX/MIN button (2).
 - ⇒ The MAX indication (10) appears on the display.
 - ⇒ The display now indicates the highest sound level measured since the device was switched on.
2. Press the MAX/MIN button (2) again.
 - ⇒ The MIN indication (8) appears on the display.
 - ⇒ The display now indicates the lowest sound level measured since the device was switched on.
3. Press the MAX/MIN button (2) for 2 seconds.
 - ⇒ The MAX/MIN function is deactivated and the current measured value is displayed.

Switching the device off

1. Press the power button (7).
 - ⇒ The device is switched off.
 - ⇒ The MAX and MIN values are reset.

The device comes equipped with an automatic switch-off function. After 15 minutes of non-use the device switches off automatically.

Errors and faults

The device has been checked for proper functioning several times during production. If malfunctions occur nonetheless, check the device according to the following list.

For repairs or device testing, contact the manufacturer.

Display segments are only faintly visible or flicker:

- The battery voltage is too low. Exchange the batteries immediately.

The device displays implausible measured values:

- The battery voltage is too low. Exchange the batteries immediately.

Maintenance and repair

Battery change

A battery change is required, when the displayed values are difficult to read, when the measured values are implausible, or if the device can no longer be switched on. See chapter Operation.

Cleaning

Clean the device with a soft, damp and lint-free cloth. Make sure that no moisture enters the housing. Do not use any sprays, solvents, alcohol-based cleaning agents or abrasive cleaners, but only clean water to moisten the cloth.

Repair

Do not modify the device or install any spare parts. For repairs or device testing, contact the manufacturer.

Disposal

Always dispose of packing materials in an environmentally friendly manner and in accordance with the applicable local disposal regulations.



The icon with the crossed-out waste bin on waste electrical or electronic equipment is taken from Directive 2012/19/EU. It states that this device must not be disposed of with the household waste at the end of its life. You will find collection points for free return of waste electrical and electronic equipment in your vicinity. The addresses can be obtained from your municipality or local administration. You can also find out about other return options that apply for many EU countries on the website <https://hub.trotec.com/?id=45090>. Otherwise, please contact an official recycling centre for electronic and electrical equipment authorised for your country.

The separate collection of waste electrical and electronic equipment aims to enable the re-use, recycling and other forms of recovery of waste equipment as well as to prevent negative effects for the environment and human health caused by the disposal of hazardous substances potentially contained in the equipment.



In the European Union, batteries and accumulators must not be treated as domestic waste, but must be disposed of professionally in accordance with Directive 2006/66/EC of the European Parliament and of the Council of 6 September 2006 on batteries and accumulators. Please dispose of batteries and accumulators according to the relevant legal requirements.

Only for United Kingdom

According to Waste Electrical and Electronic Equipment Regulations 2013 (SI 2013/3113) (as amended) and the Waste Batteries and Accumulators Regulations 2009 (SI 2009/890) (as amended), devices that are no longer usable must be collected separately and disposed of in an environmentally friendly manner.

Trotec GmbH

Grebener Str. 7
D-52525 Heinsberg

☎ +49 2452 962-400

☎ +49 2452 962-200

✉ info@trotec.com

www.trotec.com