

EN

ORIGINAL INSTRUCTIONS
BENCH GRINDING MACHINE



Table of contents

Notes regarding the instructions 2

Safety 3

Information about the device 10

Transport and storage 12

Start-up 13

Operation 19

Errors and faults 20

Maintenance 21

Disposal 23

Declaration of conformity 23

Notes regarding the instructions

Symbols



Warning of electrical voltage

This symbol indicates dangers to the life and health of persons due to electrical voltage.



Warning of sharp object

This symbol indicates dangers to the life and health of persons due to pointed objects.



Warning of hand injuries

This symbol indicates dangers to the health of persons due to hand injuries.



Warning

This signal word indicates a hazard with an average risk level which, if not avoided, can result in serious injury or death.



Caution

This signal word indicates a hazard with a low risk level which, if not avoided, can result in minor or moderate injury.

Note

This signal word indicates important information (e.g. material damage), but does not indicate hazards.



Info

Information marked with this symbol helps you to carry out your tasks quickly and safely.



Follow the manual

Information marked with this symbol indicates that the instructions must be observed.



Wear hearing protection

Information marked with this symbol indicates that you should wear hearing protection.



Wear safety glasses

Information marked with this symbol indicates that you should wear eye protection.



Wear a protective mask

Information marked with this symbol indicates that you should wear a protective mask.



Wear protective clothing

Information marked with this symbol indicates that you should wear protective clothing.



Wear protective gloves

Information marked with this symbol indicates that you should wear protective gloves.



Warning of defective sanding discs!

Information marked with this symbol indicates that defective sanding discs must not be used.

You can download the current version of the instructions via the following link:



PBGS 10-120



<https://hub.trotec.com/?id=46396>

Safety

General Power Tool Safety Warnings



Warning

Read all safety warnings, instructions, illustrations and specifications provided with this power tool.

Failure to follow all instructions listed below may result in electric shock, fire and/or serious injury.

Save all warnings and instructions for future reference.

The term *power tool* in the warnings refers to your mains-operated (corded) power tool or battery-operated (cordless) power tool.



General Power Tool Safety Warnings – Work area safety

- **Keep work area clean and well lit.** Clutter or dark areas invite accidents.
- **Do not operate power tools in explosive atmosphere, such as in the presence of flammable liquids, gases or dust.** Power tools create sparks which may ignite the dust or fumes.
- **Keep children and bystanders away while operating a power tool.** Distractions can cause you to lose control.



General Power Tool Safety Warnings – Electrical safety

- **Power tool plugs must match the outlet. Never modify the plug in any way. Do not use any adapter plugs with earthed (grounded) power tools.** Unmodified plugs and matching outlets will reduce risk of electric shock.
- **Avoid body contact with earthed or grounded surfaces, such as pipes, radiators, ranges and refrigerators.** There is an increased risk of electric shock if your body is earthed or grounded.
- **Do not expose power tools to rain or wet conditions.** Water entering a power tool will increase the risk of electric shock.
- **Do not abuse the cord. Never use the cord for carrying, pulling or unplugging the power tool. Keep cord away from heat, oil, sharp edges or moving parts.** Damaged or entangled cords increase the risk of electric shock.
- **When operating a power tool outdoors, use an extension cord suitable for outdoor use.** Use of a cord suitable for outdoor use reduces the risk of electric shock.
- **If operating a power tool in a damp location is unavoidable, use a residual current device (RCD) protected supply.** Use of an RCD reduces the risk of electric shock.



General Power Tool Safety Warnings – Personal safety

- **Stay alert, watch what you are doing and use common sense when operating a power tool. Do not use a power tool while you are tired or under the influence of drugs, alcohol or medication.** A moment of inattention while operating power tools may result in serious personal injury.
- **Use personal protective equipment. Always wear eye protection.** Protective equipment such as a dust mask, non-skid safety shoes, hard hat or hearing protection used for appropriate conditions will reduce personal injuries.
- **Prevent unintentional starting. Ensure the switch is in the off-position before connecting to power source and/or battery pack, picking up or carrying the tool.** Carrying power tools with your finger on the switch or energising power tools that have the switch on invites accidents.
- **Remove any adjusting key or wrench before turning the power tool on.** A wrench or a key left attached to a rotating part of the power tool may result in personal injury.
- **Do not overreach. Keep proper footing and balance at all times.** This enables better control of the power tool in unexpected situations.
- **Dress properly. Do not wear loose clothing or jewellery. Keep your hair and clothing away from moving parts.** Loose clothes, jewellery or long hair can be caught in moving parts.
- **Do not let familiarity gained from frequent use of tools allow you to become complacent and ignore tool safety principles.** A careless action can cause severe injury within a fraction of a second.

**General Power Tool Safety Warnings – Power tool use and care**

- **Do not force the power tool. Use the correct power tool for your application.** The correct power tool will do the job better and safer at the rate for which it was designed.
- **Do not use the power tool if the switch does not turn it on and off.** Any power tool that cannot be controlled with the switch is dangerous and must be repaired.
- **Disconnect the plug from the power source and/or remove the battery pack, if detachable, from the power tool before making any adjustments, changing accessories, or storing power tools.** Such preventive safety measures reduce the risk of starting the power tool accidentally.
- **Store idle power tools out of the reach of children and do not allow persons unfamiliar with the power tool or these instructions to operate the power tool.** Power tools are dangerous in the hands of untrained users.
- **Maintain power tools and accessories. Check for misalignment or binding of moving parts, breakage of parts and any other condition that may affect the power tool's operation. If damaged, have the power tool repaired before use.** Many accidents are caused by poorly maintained power tools.
- **Keep cutting tools sharp and clean.** Properly maintained cutting tools with sharp cutting edges are less likely to bind and are easier to control.
- **Use the power tool, accessories and tool bits etc. in accordance with these instructions, taking into account the working conditions and the work to be performed.** Use of the power tool for operations different from those intended could result in a hazardous situation.
- **Keep handles and grasping surfaces dry, clean and free from oil and grease.** Slippery handles and grasping surfaces do not allow for safe handling and control of the tool in unexpected situations.

**General Power Tool Safety Warnings – Service**

- **Have your power tool serviced by a qualified repair person using only identical replacement parts.** This will ensure that the safety of the power tool is maintained.

**Safety instructions for table sanders**

- **Do not use a damaged accessory. Before each use inspect the accessory such as sanding discs for chips and cracks and wire brushes for loose or cracked wires. After inspecting and installing an accessory, position yourself and bystanders away from the plane of the rotating accessory and run the power tool at maximum no-load speed for 1 min.** Damaged accessories will normally break apart during this test time.
- **Only use sanding discs with a speed level that is correspondingly equal to or higher than the device's idle speed. Never use defective sanding discs.** When having replaced the sanding discs, carry out a test run of at least 1 minute. Switch the device off immediately if the sanding disc is running out of centre, considerable vibrations occur or abnormal noises can be heard.
- **Never use the device without a protective cover / spark deflector.**
- **Do not use any bushings or adapters to adapt sanding discs with a large hole.**
- **Do not use any saw blades as accessories in the device.**
- **Do not use any bushings or adapters to adapt sanding discs with a large hole.**
- **The rated speed of the accessory must be at least equal to the maximum speed marked on the power tool.** Accessories running faster than their rated speed can break and fly apart.
- **Be aware that wire bristles are thrown by the wire brushes even during ordinary operation. Do not overstress the wires by applying excessive load to the brush.** The wire bristles can easily penetrate light clothing and/or skin.
- **Never grind on the lateral surfaces of the sanding discs.** Grinding on the lateral surfaces can make the sanding discs crack up and fly apart.



Safety Warnings Common for Grinding, Sanding, Wire Brushing, Polishing or Abrasive Cutting-Off Operations

- **Do not use accessories which are not specifically designed and recommended by the tool manufacturer.** Just because the accessory can be attached to your power tool, it does not assure safe operation.
- **The rated speed of the accessory must be at least equal to the maximum speed marked on the power tool.** Accessories running faster than their rated speed can break and fly apart.
- **The outside diameter and the thickness of your accessory must be within the capacity rating of your power tool.** Incorrectly sized accessories cannot be adequately guarded or controlled.
- **Abrasive wheels, abrasive rolls or other accessories must fit exactly on the grinder spindle or collet chuck of your power tool.** Accessories that do not precisely match the holder of the power tool will run out of balance, vibrate excessively and may cause loss of control.
- **Wheels, abrasive cylinders, cutting tools or other accessories mounted on a mandrel must be fully inserted into the collet chuck or jaw chuck. The “protrusion” or the exposed part of the mandrel between the abrasive accessory and the collet chuck or jaw chuck must be minimal.** If the mandrel is not sufficiently tensioned or the abrasive accessory protrudes too far forward, the accessory may become loose and be ejected at high speed.
- **Do not use a damaged accessory. Before each use inspect the accessory such as abrasive wheels for chips and cracks, abrasive rolls for cracks, tear or excess wear, wire brushes for loose or cracked wires. If power tool or accessory is dropped, inspect for damage or install an undamaged accessory. After inspecting and installing an accessory, position yourself and bystanders away from the plane of the rotating accessory and run the power tool at maximum no-load speed for one minute.** Damaged accessories will normally break apart during this test time.
- **Wear personal protective equipment. Depending on application, use face shield, safety goggles or safety glasses. As appropriate, wear dust mask, hearing protectors, gloves and workshop apron capable of stopping small abrasive or workpiece fragments.** The eye protection must be capable of stopping flying debris generated by various operations. The dust mask or respirator must be capable of filtering particles generated by your operation. Prolonged exposure to high intensity noise may cause hearing loss.
- **Keep bystanders a safe distance away from work area. Anyone entering the work area must wear personal protective equipment.** Fragments of workpiece or of a broken accessory may fly away and cause injury beyond immediate area of operation.
- **Hold the power tool by insulated gripping surfaces only, when performing an operation where the cutting accessory may contact hidden wiring or its own cord.** Cutting accessory contacting a "live" wire may make exposed metal parts of the power tool "live" and could give the operator an electric shock.
- **Always hold onto the power tool firmly when starting it.** When running up to full speed, the reaction torque of the motor can cause the power tool to twist.
- **If possible, use clamps to hold the workpiece in place. Never hold a small workpiece in one hand and the power tool in the other while using it.** Tightly clamping small workpieces allows you to have both hands free and to have better control of the power tool. When removing round workpieces such as wooden dowels, bar stock or pipes, they tend to roll away, causing the accessory to jam and be catapulted towards you.
- **Keep the connecting cable away from spinning accessories.** If you lose control of the device, the cord may be cut or snagged and your hand or arm may be pulled into the spinning accessories.
- **Never lay the power tool down until the accessory has come to a complete stop.** The spinning accessory may grab the surface and pull the power tool out of your control.

- **After changing accessories or making adjustments to the device, firmly tighten the collet chuck nut, the jaw chuck or other fixing elements.** Loose fixing elements can shift unexpectedly and cause loss of control; and rotating components that are not attached will be forcefully ejected.
- **Do not run the power tool while carrying it at your side.** Accidental contact with the spinning accessory could snag your clothing, pulling the accessory into your body.
- **Regularly clean the power tool's air vents.** The motor's fan will draw the dust inside the housing and excessive accumulation of powdered metal may cause electrical hazards.
- **Do not operate the power tool near flammable materials.** Sparks could ignite these materials.
- **Do not use accessories that require liquid coolants.** Using water or other liquid coolants may result in electrocution or shock.



Kickback and Related Warnings

A kickback is a sudden reaction to a pinched or snagged rotating wheel, abrasive wheel, abrasive belt, brush or any other accessory. Pinching or jamming causes rapid stalling of the rotating accessory. This will accelerate an uncontrolled power tool towards the direction opposite of the accessory's rotation.

For example, if an abrasive wheel is snagged or pinched by the workpiece, the edge of the wheel that is entering into the pinch point can dig into the surface of the material causing the wheel to climb out or kick out. The wheel may either jump toward or away from the operator, depending on direction of the wheel's movement at the point of pinching. Abrasive wheels may also break under these conditions.

Kickback is the result of power tool misuse and/or incorrect operating procedures or conditions. Kickback can be avoided by taking proper precautions as given below.

- **Maintain a firm grip on the power tool and position your body and arm to allow you to resist kickback forces.** The operator can control kickback forces, if proper precautions are taken.
- **Never place your hand near the rotating accessory.** Accessory may kickback over your hand.
- **Use special care when working corners, sharp edges etc. Avoid bouncing and snagging the accessory.** Corners, sharp edges or bouncing have a tendency to snag the rotating accessory. The result would be a loss of control or kickback.
- **Do not attach a saw chain woodcarving blade or toothed saw blade.** Such blades create frequent kickback and loss of control.
- **Always move the accessory into the material in the same direction in which the cutting edge leaves the material (corresponds to the same direction in which the chips are ejected).** Guiding the power tool in the wrong direction causes the cutting edge of the accessory to climb out of the workpiece, which will pull the power tool in that feed direction.
- **Always clamp the workpiece firmly when using rotary files, cutting wheels, high-speed milling tools or carbide milling tools.** If these accessories become only slightly jammed in the groove, they will get caught and may cause a kickback. If a cutting wheel gets caught, it usually breaks. If rotary files, high-speed milling tools or carbide milling tools get caught, the tool insert may be ejected from the groove and cause loss of control of the power tool.

Safety Warnings Specific for Grinding and Abrasive Cutting-Off Operations

- **Only use abrasives approved for your power tool and for the recommended applications. Example: do not grind with the side of cut-off wheel.** Cutting discs are designed for material removal using the edge of the disc. Exerting force to the sides of these abrasives may break them.
- **For conical and straight abrasive pencils with a thread, only use undamaged mandrels of the correct size and length without an undercut on the shoulder.** Suitable mandrels reduce the risk of breakage.
- **Do not "jam" the cut-off wheel or apply excessive pressure. Do not attempt to make an excessive depth of cut.** Overstressing the wheel increases the loading and susceptibility to twisting or binding of the wheel in the cut and the possibility of kickback or wheel breakage.
- **Do not position your hand in line with and behind the rotating cutting wheel.** When the wheel, at the point of operation, is moving away from your hand, the possible kickback may propel the spinning wheel and the power tool directly at you.
- **When wheel is binding or when interrupting a cut for any reason, switch off the power tool and hold the power tool motionless until the wheel comes to a complete stop. Never attempt to remove the cut-off wheel from the cut while the wheel is in motion otherwise kickback may occur.** Investigate and take corrective action to eliminate the cause of wheel binding.
- **Do not restart the cutting operation in the workpiece. Let the wheel reach full speed and carefully re-enter the cut.** The wheel may bind, walk up or kickback if the power tool is restarted in the workpiece.
- **Support panels or any oversized workpiece to minimize the risk of wheel pinching and kickback.** Large workpieces tend to sag under their own weight. Supports must be placed under the workpiece near the line of cut and near the edge of the workpiece on both sides of the wheel.
- **Use extra caution when making a pocket cut into existing walls or other blind areas.** The protruding wheel may cut gas or water pipes, electrical wiring or objects that can cause kickback.

Safety Warnings Specific for Wire Brushing Operations

- **Be aware that wire bristles are thrown by the brush even during ordinary operation. Do not overstress the wires by applying excessive load to the brush.** The wire bristles can easily penetrate light clothing and/or skin.
- **Let brushes run at operating speed for at least one minute before starting work. Make sure that during this time no other person is standing in line with the brush.** During the start-up time, loose wire bristles may fly.
- **Direct the rotating wire brush away from yourself.** When working with these brushes, small particles and tiny bits of wire may fly at high speed and penetrate the skin.

Additional safety instructions for portable table sanders

- **Before every application, ensure that the sanding discs are free from defects.** Also carry out a ring test for detecting cracks. To do so, lightly strike the disc on the right-hand and left-hand side from the vertical centre line using a non-metallic hammer. The light striking should produce a bright, bell-like sound. Do not use the disc if the sound is dull.
- **Adjust the spark deflectors at regular intervals in order to compensate for wear of the disc, keeping the distance between the spark deflector and the disc as small as possible and in no case letting it exceed 2 mm.** Replace the sanding disc if the spark deflector can no longer be adjusted to the distance required.
- Only use the power tool with accessories that are mounted on both spindles. In this way, contact with the rotating spindle is prevented.
- Always use the protective cover, the workpiece support, the protective screens and the spark deflectors as required by the accessory.
- Replace damaged or strongly furrowed sanding discs.
- When transporting the table sander, lift it at the housing or at the two protective covers.
- Adjust the workpiece supports so that the angle between the workpiece support and the accessory is always greater than 85°.
- Only use sanding discs with a thickness of 20 mm and a hole diameter of 10 mm.
- Always provide for stable and secure conditions for the table sander when you mount it on a workbench or a similar surface.
- Ensure that the grinding functions are carried out safely.

Intended use

Only use the device PBGS 10-120 for:

- grinding into wood or metal
- polishing
- sharpening tools, e.g. knives, scissors, chisels

In combination with the flexible shaft:

- Milling into wood or plastics
- For sawing and cutting
 - Wood
 - Plastics
 - Non-ferrous metals
 - Fixing elements
(e.g. screws, nails, clamps etc.)
- For sanding small, dry areas
- Engraving
 - Metal
 - Plastics
 - Glass
 - Ceramics
 - Wood
 - Leather
- Polishing

whilst adhering to the technical data.

We recommend using the power tool with original Trotec accessories.

Foreseeable misuse

Do not use the device for:

- cutting up tiles
- sawing large screws or stainless steel
- Processing workpieces requiring a continuous water supply
- drilling into concrete or natural stone

Only use the device in weatherproof surroundings.

Do not use the device in humid or wet rooms and surroundings.

The device is not suitable for commercial continuous use.

Any other use than the one described in the chapter "Intended use" is regarded as reasonably foreseeable misuse.

Personnel qualifications

People who use this device must:

- have read and understood the instructions, especially the Safety chapter.

Personal protective equipment



Wear hearing protection.

Excessive noise can lead to hearing loss.



Wear eye protection.

With it you protect your eyes from splintering, falling and flying pieces which could cause injuries.



Wear a protective mask.

It saves you from inhaling harmful dusts generated when processing workpieces.



Wear protective gloves.

They protect your hands from burns, crushing injuries and skin abrasions.



Wear tight-fitting protective clothing.

This protects you from the draw-in and entanglement hazard posed by rotating parts.



Wear safety boots.

They protect your feet from splintering, falling and flying pieces which could cause injuries.

Residual risks



Warning of electrical voltage

Electric shock from insufficient insulation.

Check the device for damages and proper functioning before each use.

If you notice damages, no longer use the device.

Do not use the device when the device or your hands are damp or wet!



Warning of electrical voltage

Work on the electrical components must only be carried out by an authorised specialist company!



Warning of electrical voltage

There is a risk of a short-circuit due to liquids penetrating the housing!

Do not immerse the device and the accessories in water. Make sure that no water or other liquids can enter the housing.



Warning of hot surface

The insertion tool might still be hot after the application. Burn hazard when touching the insertion tool.



Do not touch the insertion tool bare-handed!
Wear protective gloves!

**Warning of hot surface**

If the flexible shaft forms a loop or becomes kinked during operation, the shaft can heat up and melt with the hose. Ensure that the flexible shaft does not become kinked or heated up and do not burn yourself. Wear protective gloves!

**Warning**

Toxic dusts!

The harmful / toxic dusts produced during operation pose of risk to the health of the operator and persons in the vicinity.

Wear eye protection and a dust mask!

**Warning**

Do not process materials containing asbestos. Asbestos is considered carcinogenic.

**Warning**

Risk of injuries caused by flying parts or bursting tool heads.

**Warning**

Dangers can occur at the device when it is used by untrained people in an unprofessional or improper way! Observe the personnel qualifications!

**Warning**

The device is not a toy and does not belong in the hands of children.

**Warning**

Risk of suffocation!

Do not leave the packaging lying around. Children may use it as a dangerous toy.

**Caution**

Vibration emissions can cause a health hazard if the device is used for an extended period of time or if it is not properly handled and maintained.

**Caution**

Keep a sufficient distance from heat sources.

Note

If you store or transport the device improperly, the device may be damaged.

Note the information regarding transport and storage of the device.

Behaviour in the event of an emergency / emergency stop function

Emergency stop:

Removing the mains plug from the mains socket results in the function of the device immediately stopping. In order to secure the device against accidental switch-on, leave the mains plug disconnected.

Behaviour in the event of an emergency:

1. Switch the device off.
2. In an emergency, disconnect the device from the mains feed-in: Hold onto the mains plug while pulling the power cable out of the mains socket.
3. Do not reconnect a defective device to the mains.

Information about the device

Device description

The device PBGS 10-120 is a stationary sander for dry grinding with a sanding disc (grain size 120) and a polishing disc (grain size 400).

For material-compatible working, the nominal speed can be set steplessly within a range of 0 –11,500 rpm at the setting wheel.

The highly flexible shaft supplied allows for the performance of especially fine and detailed tasks in the fields of drilling, milling, cutting, engraving or polishing. It is suited for activities like model construction and the use in wood and metal processing or for polishing jewellery.

The device furthermore offers spark protection with swivel-mounted protective screens for safe working.

Device depiction

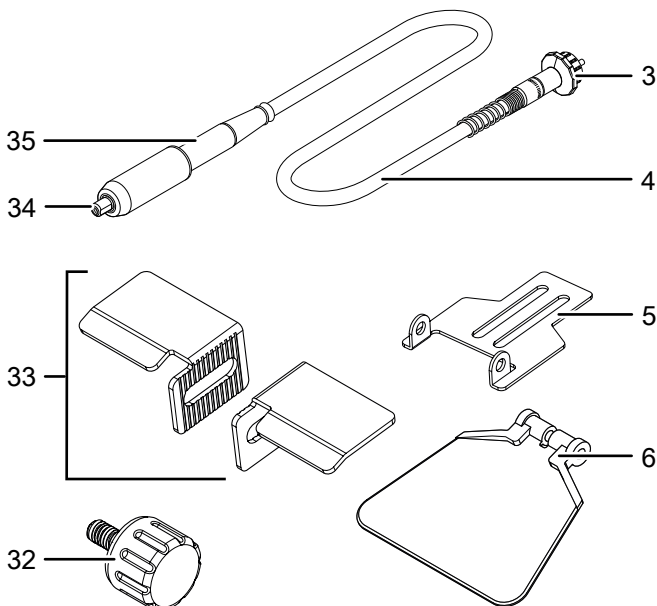
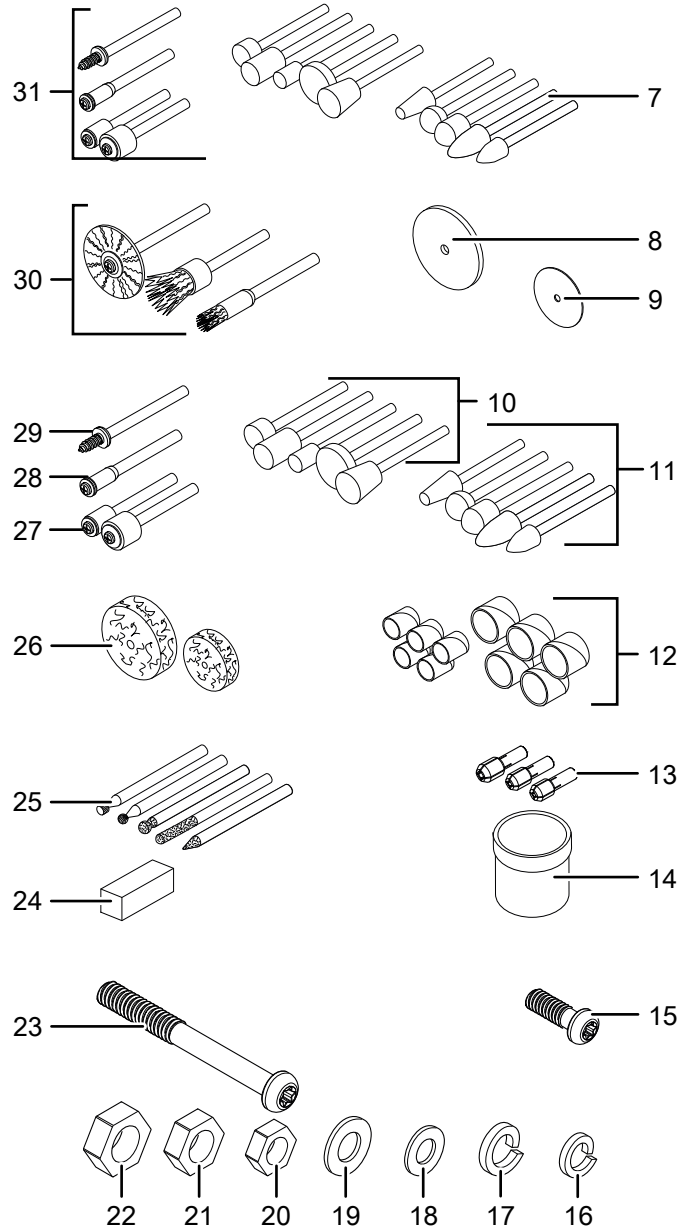
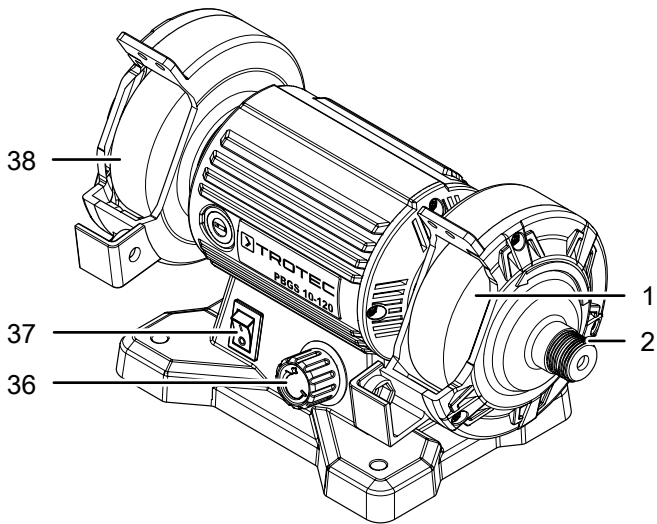

No.	Designation
1	Machine polishing disc
2	Connection thread for flexible shaft
3	Lock nut for flexible shaft
4	Flexible shaft
5	Spark deflector
6	Protective glass
7	Wrench
8	Sanding discs
9	Cutting discs
10	Corundum grinding head (different types)
11	Aluminium oxide grinding head (different types)
12	Abrasive belts
13	Set of collet chucks
14	Polishing compound
15	Threaded screw M4 x 10 mm
16	Spring washer M4
17	Spring washer M5
18	Flat washer M4
19	Flat washer M5
20	Threaded nut M4
21	Threaded nut M5
22	Threaded nut M6
23	Threaded screw M5 x 45 mm
24	Grinding stone
25	Set of milling bits
26	Polishing attachments
27	Mandrel for abrasive belts
28	Mandrel for cutting discs/sanding discs
29	Mandrel for polishing attachments
30	Set of brass brushes
31	Set of cleaning brushes
32	Knurled screw
33	Workpiece supports
34	Tool holder
35	Handle of flexible shaft
36	Setting wheel for speed selection
37	On/off switch
38	Machine sanding disc

Scope of delivery

- 1 x Device PBGS 10-120
- 1 x Flexible shaft
- 2 x Spark deflectors
- 2 x Protective glasses
- 2 x Workpiece supports
- 1 x Wrench
- 12 x Cutting discs 32 x 1 mm
- 40 x Sanding discs 24 mm
- 5 x Abrasive belts 13 mm, 15 mm
- 5 x Abrasive belts 13 mm, 9 mm
- 5 x Polishing attachments 7 mm x 25 mm
- 5 x Polishing attachments 7 mm x 13 mm
- 5 x Aluminium oxide grinding heads
- 5 x Corundum grinding heads
- 5 x Milling cutters (groove, ball head, bevel)
- 1 x Grinding stone
- 3 x Collet chucks (3.2 mm / 2.4 mm / 2.0 mm / 2.4 mm / 3.2 mm)
- 1 x Polishing paste
- 2 x Mandrels for abrasive belts
- 2 x Mandrels for cutting/sanding discs, polishing felt
- 3 x Brass brushes
- 4 x Cleaning brushes
- 1 x Storage box
- 2 x Knurled screws
- 2 x Nuts M6
- 2 x Nuts M5
- 4 x Nuts M4
- 2 x Threaded screws M5 x 45 mm
- 4 x Threaded screws M4 x 10 mm
- 2 x Flat washers M5
- 4 x Flat washers M4
- 2 x Spring washers M5
- 4 x Spring washers M4
- 1 x manual

Technical data

Parameter	Value
Model	PBGS 10-120
Nominal voltage	230 V / 50 Hz
Power consumption	120 W
Nominal idle speed n_0	0 - 11,500 rpm
Operating speed	45 m/s
Weight	2 kg
Sanding disc diameter	75 mm
Hole diameter of the sanding disc	10 mm
Sanding disc thickness	20 mm
Sanding disc hardness grade	M
Cable length	2 m
Protection class	II (double insulation) / <input type="checkbox"/>
Type of protection	IPX0
Sound values in accordance with EN 62841-1	
Sound pressure level L_{pA}	86 dB (A)
Sound power L_{WA}	99 dB(A)
Uncertainty K	3 dB



Wear hearing protection.

Excessive noise can lead to hearing loss.

Notes relating to noise information:

- The **noise emission values** specified were measured by means of a test procedure standardised in EN 62841 and can be consulted for the comparison of one power tool with another.
- The **noise emission values** specified can also be used for preliminary load assessment.
- The actual **noise emission** may differ from the stated values during operation of the power tool. This depends on how the power tool is used and especially on the type of workpiece being processed. Try to keep the load caused by noise emission at a minimum level. All parts of an operating cycle must be taken into consideration for this (e.g. times at which the power tool is switched off and times when it is switched on but runs without load).

Transport and storage

Note

If you store or transport the device improperly, the device may be damaged.

Note the information regarding transport and storage of the device.

Transport

Before transporting the device, observe the following:

- Switch off the device.
- Hold onto the mains plug while pulling the power cable out of the mains socket.
- Disassemble the flexible shaft.
- Allow the device to cool down.
- When transporting the table sander, lift it at the housing or at the two protective covers.

Storage

Before storing the device, observe the following:

- Switch off the device.
- Hold onto the mains plug while pulling the power cable out of the mains socket.
- Disassemble the flexible shaft.
- Allow the device to cool down.
- Clean the device as described in the Maintenance chapter.

When the device is not being used, observe the following storage conditions:

- dry and protected from frost and heat
- Ambient temperature below 45 °C
- Protected from dust and direct sunlight
- Store the insert tools and other accessories in the storage box.

Start-up

Unpacking the device

- Take the device and the accessories out of the packaging.



Warning of electrical voltage

Electric shock from insufficient insulation.
Check the device for damages and proper functioning before each use.

If you notice damages, no longer use the device.

Do not use the device when the device or your hands are damp or wet!

- Check the contents for completeness and look for damages.



Warning

Risk of suffocation!

Do not leave the packaging lying around. Children may use it as a dangerous toy.

- Dispose of the packaging material according to the national regulations.

Table assembly (optional)

Note

The screws and nuts required for the assembly are not included in the scope of delivery.

1. Position the device on a suitable base (e.g. table or workbench).
2. Mark the holes on the device base through the 4 holes for table assembly.
3. Remove the device and drill the holes into the base.
4. Insert the screws into the 4 holes for table assembly on the device base.
5. Screw the device to the base (e.g. table or workbench) using 4 screws and nuts.

Assembly of the workpiece supports

Note

Assembly of the workpiece supports (33) must be carried out ensuring that the distance between the sanding or polishing disc and the two workpiece supports (33) is as small as possible. The distance may amount to maximally 2 mm. Make sure that the workpiece supports (33) do not touch the sanding or polishing disc. Adjust the distance of the workpiece supports (33) to the sanding or polishing discs at regular intervals, in order to balance out wear and tear of the sanding or polishing discs.

The workpiece support (33) is not pre-assembled in the as-delivered condition and has to be mounted on the device prior to initial start-up.

1. Insert the nut (22) into the matching recess on the mounting flange (39) of the workpiece support and hold it in place with your finger.
2. Push the knurled screw (32) through the groove of the workpiece support (33) and screw both items together using the nut (22) on the mounting flange (39).
3. Adjust the workpiece support (33) so that the distance to the sanding or polishing disc is less than 2 mm. In doing this, observe that the angle is always greater than 85°.
4. Repeat this assembly process on the other side of the device.

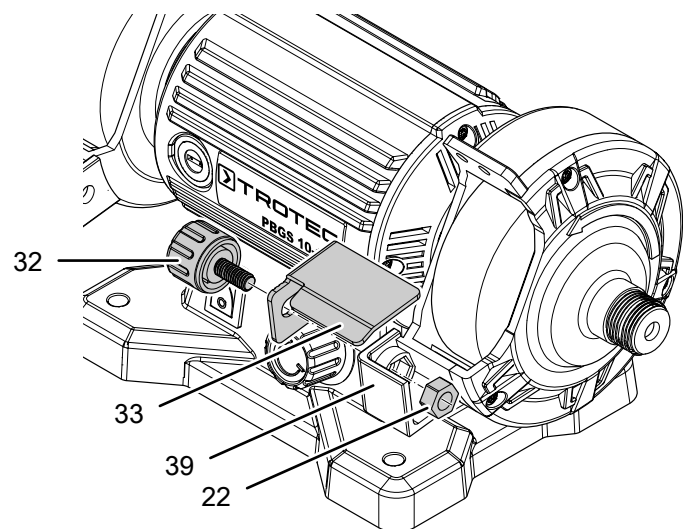

Assembly of the spark deflectors

The two spark deflectors (5) are possibly not pre-assembled in the as-delivered condition and have to be mounted on the device prior to initial start-up.

The distance to the sanding disc may amount to maximally 2 mm. Adjust this distance at regular intervals to compensate for wear and tear of the disc.

1. Place one spring washer (16) and one flat washer (18) each on the two mounting screws (15).
2. Position the spark deflectors(5) on the mounting strap (40) and put the two mounting screws (15) through the two holes on the mounting strap (40).
3. Screw the two mounting screws (15) together with one nut (20) each.

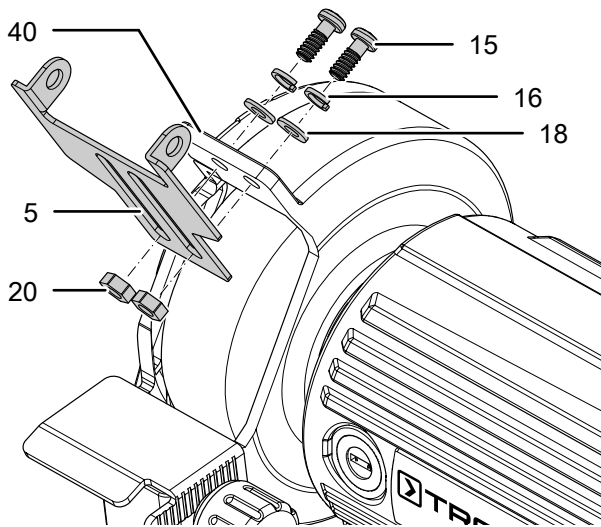

4. Repeat this assembly process on the other side of the device.

Assembly of the protective glasses

The two protective glasses (6) for the two sanding discs are possibly not pre-assembled in the as-delivered condition and have to be mounted on the device prior to initial start-up.

1. Insert the protective glass (6) into the holding fixture at the spark protection mechanism (5) and hold it in position.
2. Place the spring washer (17) and the flat washer (19) onto the mounting screw (23) and screw the protective glass (6) together with the nut (21).

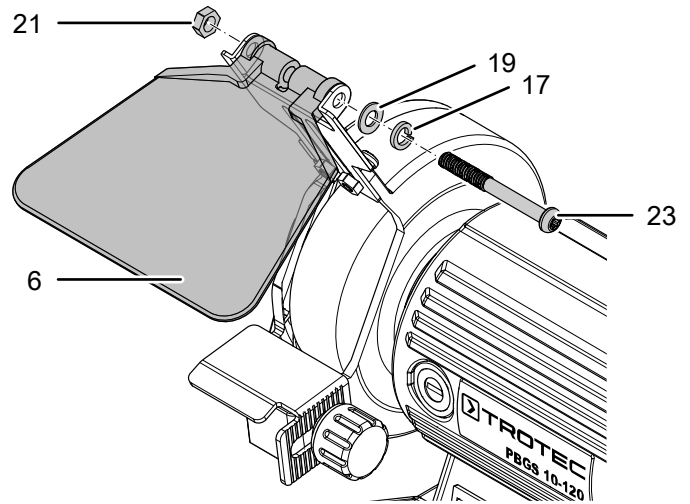

3. When tightening the screws, make sure that the protective glass (6) holds the position by itself, at the same time, however, remaining flexible.
4. Repeat this assembly process on the other side of the device.

Using a flexible shaft

Note

Never actuate the spindle lock (42) while the tool is running! This may damage the tool.



Info

Use the flexible shaft for tasks requiring fine and precise guidance of the tool.



Warning of hot surface

Ensure that the flexible shaft does not form a loop or become kinked during operation. There is a risk of the shaft becoming hot and melting with the hose. Do not touch the handle if it became hot. Risk of burns.

- ✓ The device is switched off and the mains plug is disconnected.
- 1. Place the lock nut (3) of the flexible shaft onto the connection thread (2) on the device and ensure that the square inner axis (41) of the flexible shaft engages with the holding fixture of the flexible shaft (49).
- 2. Tighten the lock nut (3) in counter-clockwise direction.

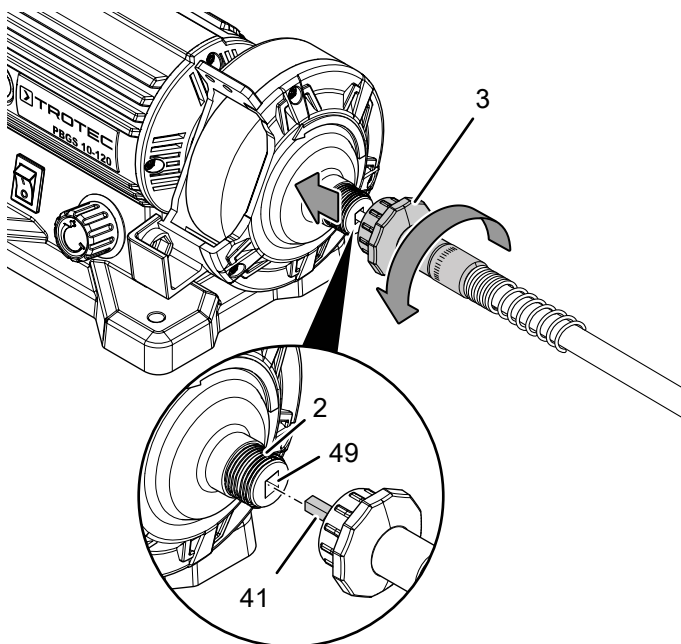

Tool change



Wear protective gloves

Wear appropriate protective gloves when inserting or exchanging tools.

Proceed as follows to clamp a tool on the handle (35) of the flexible shaft:

- ✓ The device is switched off and the mains plug is disconnected.
- 1. In order to block the spindle, pull back the spindle lock (42) on the handle (35) and hold the position.
- 2. Loosen the clamping nut (43) by means of the wrench (7) by turning it in counter-clockwise direction.
- 3. Remove the tool from the tool holder (34), if any.

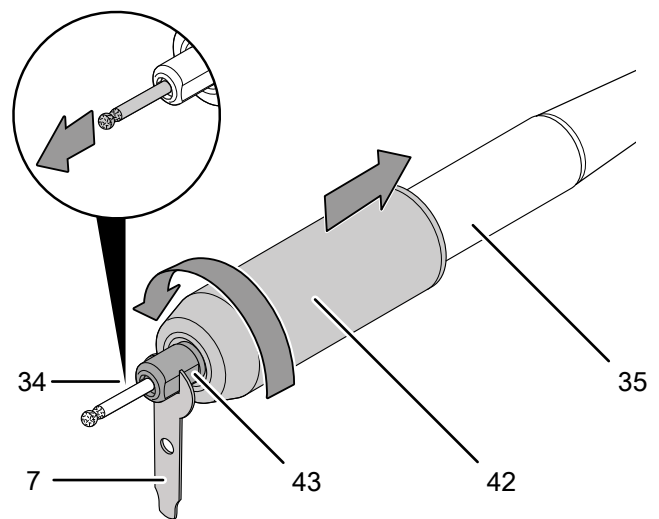

- 4. Insert the tool required into the tool holder (34).
- 5. Tighten the clamping nut (43) in clockwise direction using the wrench (7).

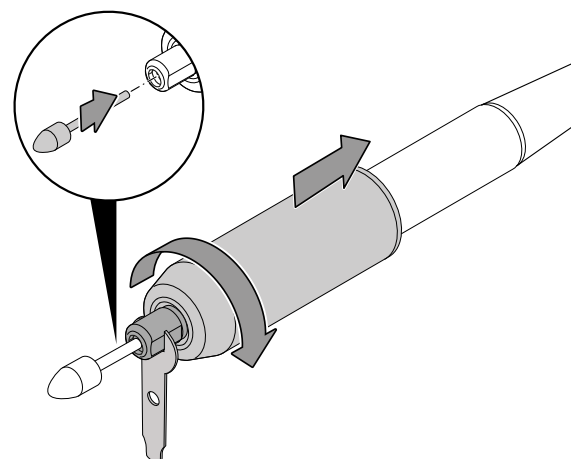

- 6. Let go of the spindle lock (42).
- 7. Check the tool for tight fit.

Using a tool with mandrel



Wear protective gloves

Wear appropriate protective gloves when inserting or exchanging tools.

The following tools are mounted by means of a corresponding mandrel:

- Polishing attachments (26)
- Cutting discs (9)
- Abrasive wheels (8)
- Abrasive belts (12)

To mount the tool on the mandrel, please proceed as follows:

Polishing attachments:

- ✓ The device is switched off and the mains plug is disconnected.
1. Insert the mandrel for polishing attachments (29) into the device as described in the "Tool change" chapter.
 2. In order to block the spindle, pull back the spindle lock (42) on the handle (35) and hold the position.
 3. Screw the polishing attachment (26) onto the thread of the mandrel in clockwise direction and then let go of the spindle lock (42) again.

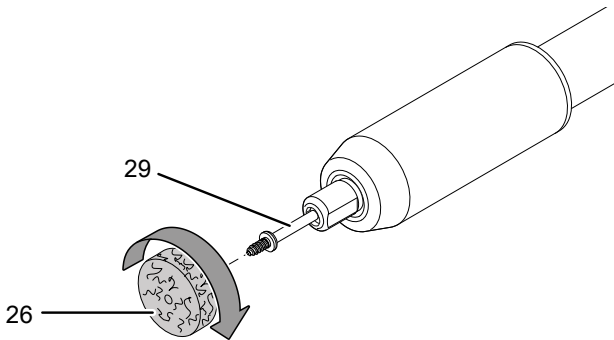

Cutting discs/sanding discs:

- ✓ The device is switched off and the mains plug is disconnected.
1. Insert the mandrel for cutting discs / sanding discs (28) into the device as described in the "Tool change" chapter.
 2. In order to block the spindle, pull back the spindle lock (42) on the handle (35) and hold the position.
 3. Unscrew the screw (45) from the mandrel by turning the screw in counter-clockwise direction.

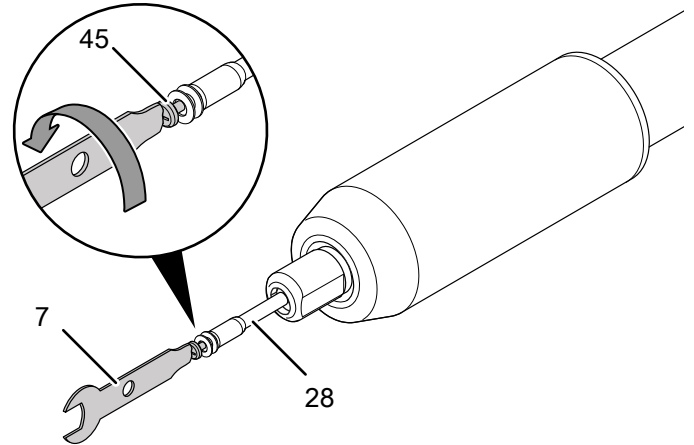

4. Place a cutting disc (9) or abrasive wheel (8) between the two washers (46) onto the screw (45) and tighten it to the mandrel again in clockwise direction.

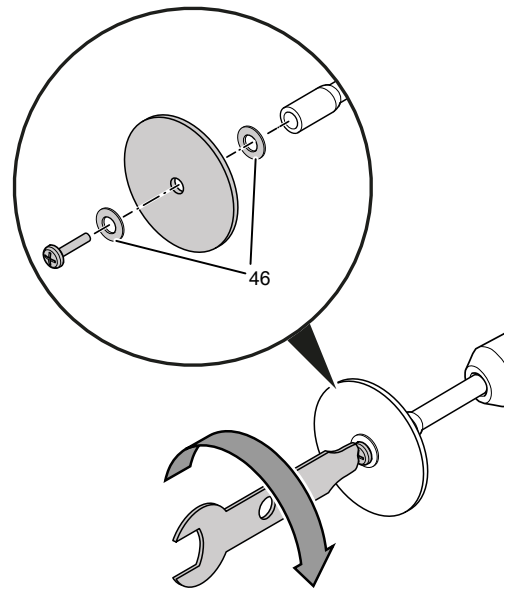

5. Let go of the spindle lock (42).

Abrasive belt:

- ✓ The device is switched off and the mains plug is disconnected.
- 1. Insert the mandrel for abrasive belts (27) into the device as described in the "Tool change" chapter.
- 2. In order to block the spindle, pull back the spindle lock (42) on the handle (35) and hold the position.
- 3. Turn the screw (45) on the mandrel in counter-clockwise direction until it has a little backlash.

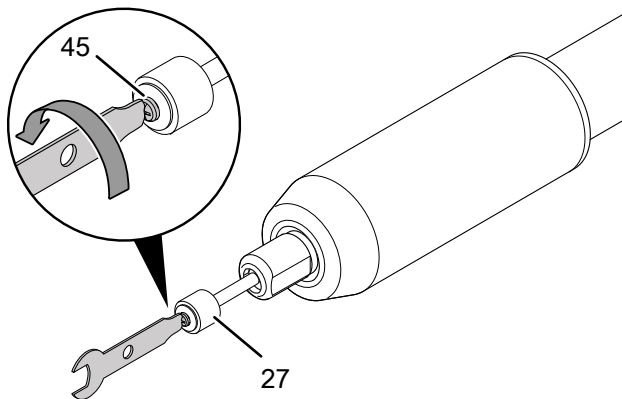

- 4. Place the abrasive belt (12) onto the rubberized holder and tighten the screw (45) again in clockwise direction.

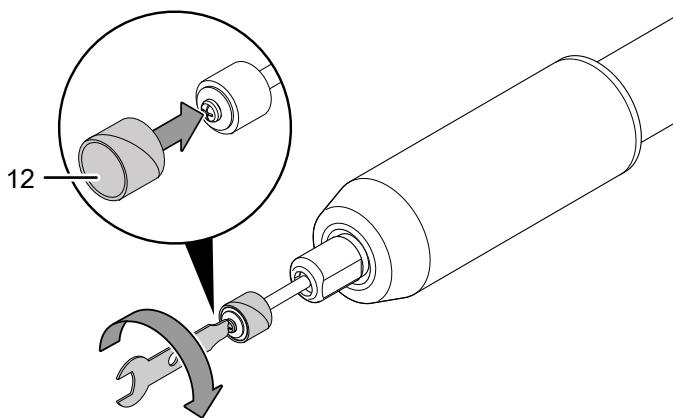

- 5. Let go of the spindle lock (42).

Replacing the collet chuck



Wear protective gloves

Wear appropriate protective gloves when inserting or exchanging tools.

Note

If, for example, you would like to use a twist drill bit or another tool with a different shank diameter than the last one used, the collet chuck must be changed.

Please proceed as follows:

- ✓ The device is switched off and the mains plug is disconnected.
- 1. In order to block the spindle, pull back the spindle lock (42) on the handle (35) and hold the position.
- 2. Unscrew the clamping nut (43) in counter-clockwise direction using the wrench (7).

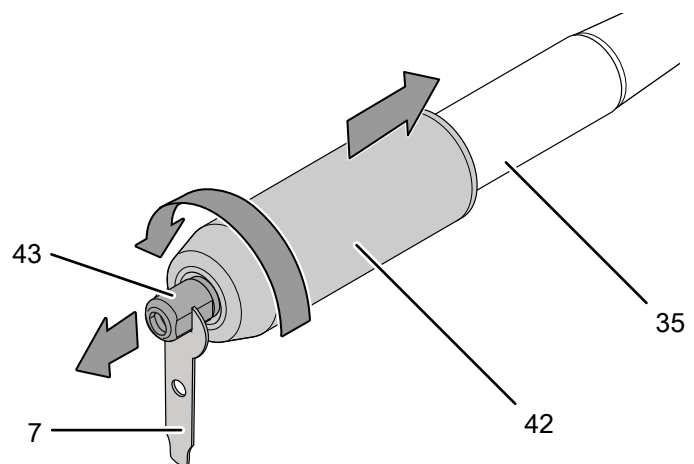

- 3. Remove the collet chuck (13) from the collet chuck holder (44).

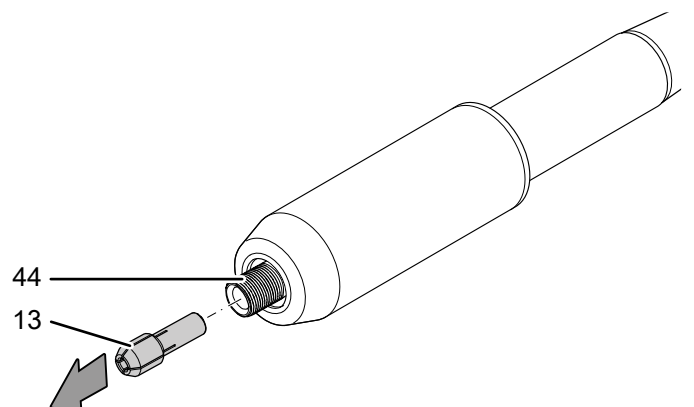

4. Insert a collet chuck (13) matching the accessory you are planning to use into the collet chuck holder (44) in.

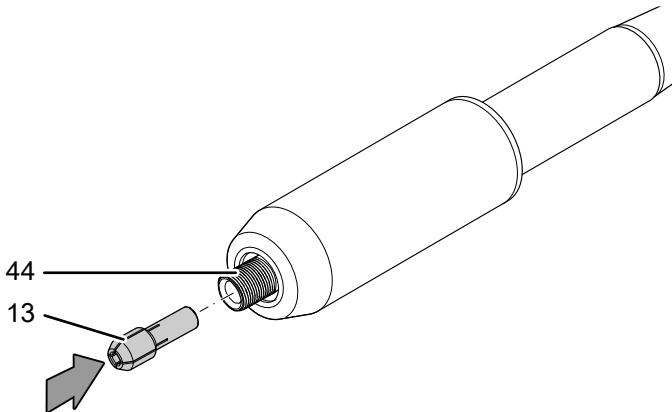

5. Screw the clamping nut (43) in clockwise direction onto the collet chuck holder (44).

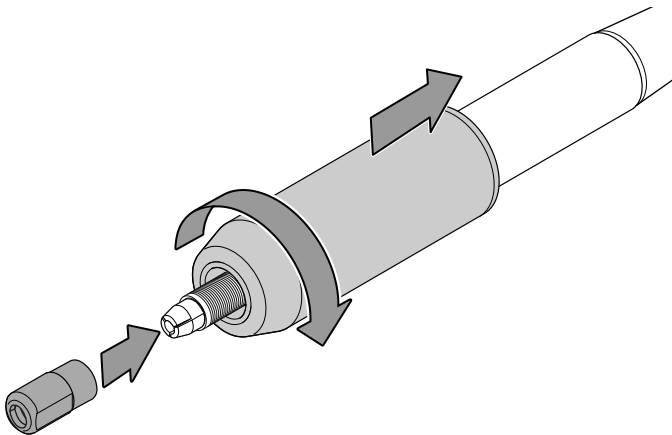

6. Let go of the spindle lock (42) again.

Speed selection

The required speed depends on the material and the operating conditions and can be determined by way of field-testing. For most tasks like grinding harder materials (e.g. wood or metal) as well as cutting, grinding and engraving using the flexible shaft, we recommend the highest speed level. Some materials (certain plastics and soft metals), however, may be damaged by the heat generated at a high speed and should therefore be processed at a correspondingly lower speed.

The setting range covers the speed range (0 - 11,500 rpm). You can change the preselected speed level at any time.

1. Turn the setting wheel (36) in clockwise direction to increase the speed.
2. Turn the setting wheel (36) in counter-clockwise direction to reduce the speed.

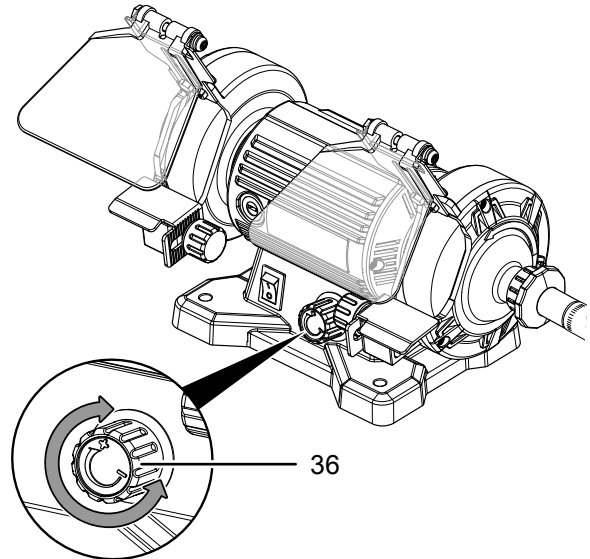

Tips and notes for selecting the correct speed level when using the sanding or polishing disc on the machine

- For grinding wood or metal, select a high speed level.
- For machining plastics or other materials with a low melting point, select a low speed level.

Tips and notes for selecting the correct speed level when using the flexible shaft

- Select a high speed level for cutting, forming, chamfering or milling grooves in the wood, and for sanding or grinding wood or metal.
- If you wish to cut plastics or other materials with a low melting point, select a low speed level.
- For drilling into wood, select a low speed level, in order to prevent the tool from being overheated
- For polishing, buffing and cleaning with a wire brush, select the lowest speed level, in order to prevent the brush from damage by bristles coming loose from the brush holder.
- For milling or drilling into non-ferrous metals, e.g.: aluminium, copper, lead, zinc alloys, select a low speed level. Additionally use a cutting oil or another suitable lubricant (not water) in order to prevent chips from settling on the cutting edges of the tool, and to prevent the tool from being overheated.

Connecting the power cable

- Insert the mains plug into a properly secured mains socket.

Operation

Tips and notes on handling the sanding or polishing disc on the machine

- Ensure stable positioning and secure footing of the device. To be on the safe side, you can fasten the device in an appropriate place (see chapter Table assembly).
- Before every application, check the sanding disc and make sure that it is not blocked.
- Before every application, ensure that the protective glasses, spark deflectors and workpiece supports are mounted properly.
- Before every application, make sure that you have selected the correct speed level for the intended use. By adapting the speed to the task you have planned and to the m to be machined, better results can be obtained.
- Bear in mind that the workpiece will be strongly heated by the sanding process. Therefore, allow the workpiece to cool down in a water bath after the grinding process. Then dry it thoroughly before you continue with its machining.

Tips and notes on handling the flexible shaft

General information:

- Check the tool in the tool holder for proper fit before every application. The tool must be firmly locked in place in the tool holder.
- Before every application, make sure that you have selected the correct tool and the correct speed for the intended use. By adapting the speed to the task you have planned and to the m to be machined, better results can be obtained.
- Always hold the tool away from your face. Parts of damaged accessories might come loose when high speeds are reached.
- Before using the tool, you should get a feel for the tool. Take the tool into your hand and familiarize yourself with its weight and centre of gravity. Use some scrap material to practise a bit and to learn how the tool responds with different speed settings.
- For tasks requiring precision, like for example engraving, polishing or sanding, you can also hold the tool between your thumb and index finger like a pen. The tapering of the housing on the lower part of the tool serves this purpose.

Cutting:

- Only use intact, flawless cutting discs. Bent, blunt or otherwise damaged cutting discs could break.
- Never use the cutting disc for roughing!
- Only advance moderately during operation and make sure that the cutting disc does not get jammed.
- Do not slow down the decelerating cutting disc by pressing against the side of the disc.
- Always move the cutting disc through the workpiece in reverse rotation.
- Hold onto the tool with both hands.

Sanding:

- Maintain a consistent grinding pressure to increase the lifetime of the abrasive wheels and abrasive belts.
- You'll obtain better results if the machining process not only involves one single work cycle, but if you move over the surface several times with the tool.

Milling:

- Provide for an even forward motion to prevent overheating of the milling cutter.
- Hold onto the tool with both hands.

Engraving:

- Hold the handle of the flexible shaft at a slight angle while performing the engraving task, similar to the position of holding a pen. Your arm should be resting on the table.
- Guide the engraving bit over the workpiece applying light grinding pressure.
- Preferably use excess material to test the feed rate.

Polishing:

- When you polish the workpiece, guide the tool over the workpiece only applying light grinding pressure.

Applying the brass brush / plastic brush

- When you polish the workpiece, guide the tool over the workpiece only applying light grinding pressure.
- For polishing, buffing or cleaning with a brass brush or plastic brush, select a low speed level to prevent the brush and material from damage.

Switching the device on and off

Wear your personal protective equipment when working with the device.

1. Check whether the fixed tool and the speed set are suitable for the intended application.
2. Check whether the workpiece is secured and the worktop prepared correspondingly.
3. Switch the device on by setting the on/off switch (37) to position **I**.

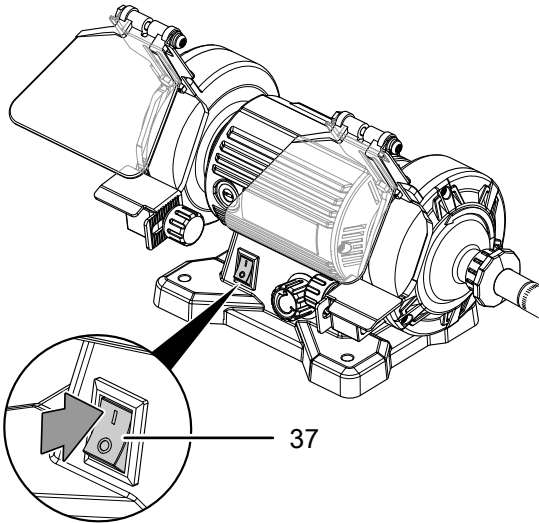

4. Switch the device off by setting the on/off switch (37) to position **0**.

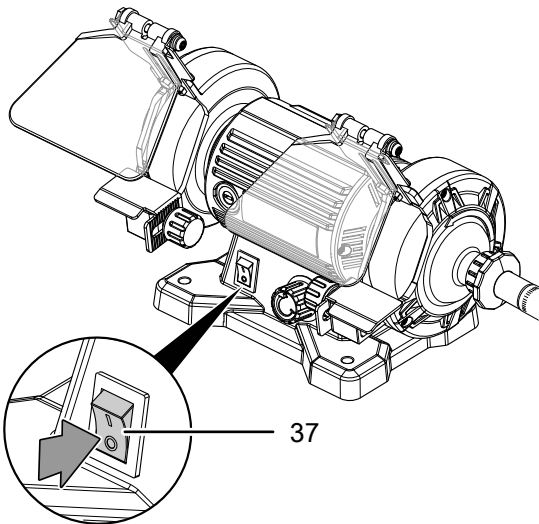

Shutdown



Warning of electrical voltage

Do not touch the mains plug with wet or damp hands.

- Switch off the device.
- Hold onto the mains plug while pulling the power cable out of the mains socket.
- If applicable, disassemble the flexible shaft.
- Clean the device according to the Maintenance chapter.
- Store the device according to the Transport and storage chapter.

Errors and faults

The device has been checked for proper functioning several times during production. If malfunctions occur nonetheless, check the device according to the following list.

Troubleshooting tasks which require the housing to be opened must only be carried out by an authorized specialist electrical company or by Trotec.



Info

Wait for at least 10 minutes after maintenance and repair work. Only then switch the device back on.

Light smoke or odour is emitted during the first use:

- This is not a fault. These phenomena disappear after a brief runtime.

The device does not start:

- Check the power connection.
- Check the power cable and mains plug for damage. If you notice damages, do not try to take the device back into operation.

If the supply cord is damaged, it must be replaced by the manufacturer, its service agent or similarly qualified persons in order to avoid a hazard.

- Check the on-site fusing.

The device becomes hot:

- Make sure not to exert too much pressure on the device during grinding.
- Check whether the tool is suitable for the tasks to be carried out.
- Keep the venting slots clear to prevent the motor from overheating.

The sanding or polishing performance decreases:

- Remove any abrasive dust using a brush.
- Check the set speed; it must be suitable for both the tool and the material.
- Ensure that the distance between the workpiece support and the spark deflector does not exceed the permissible 2 mm. If required, reduce the distance or replace the sanding disc.
- If the sanding or polishing disc is worn, replace it with a new one.

The tool is loose:

- Make sure that the clamping nut (43) is tightened properly to the tool holder.

The cutting disc has difficulties with penetrating the material to be processed or the cutting performance of the abrasive wheel is insufficient:

- Check whether the chosen tool is suitable for the material to be processed.
- Check the set speed selection. It must be suitable for both the tool and the material.
- Select a higher speed by turning the setting wheel for speed selection (36) to a higher level.
- If the cutting disc or abrasive wheel is worn, replace it with a new one.

The sanding disc is running out of centre and abnormal noises can be heard:

- Check whether the workpiece holder and/or spark deflector is adjusted incorrectly.
- Check whether the sanding disc is defective.
- Check whether the sanding disc nut is loose.

The device is running but the flexible shaft does not work:

- Check whether the inner axis (41) of the flexible shaft is fixed firmly on the connection of the flexible shaft (2).

The device still does not operate correctly after these checks:

Please contact the customer service. If necessary, bring the device to an authorised specialist electrical company or to Trotec for repair.

Maintenance

Activities required before starting maintenance



Warning of electrical voltage

Do not touch the mains plug with wet or damp hands.

- Switch off the device.
- Hold onto the mains plug while pulling the power cable out of the mains socket.
- Allow the device to cool down completely.



Warning of electrical voltage

Maintenance tasks which require the housing to be opened must only be carried out by authorised specialist companies or by Trotec.

Notes on maintenance

Inside the device, there are no parts that need to be lubricated by the user.

Replacing the sanding or polishing disc

Note

Damaged or strongly furrowed sanding and polishing discs must be replaced.

Replace damaged or strongly furrowed sanding and polishing discs .

Replace the sanding discs if the distance between the spark deflector and the workpiece supports can no longer be adjusted to ≤ 2 mm.



Warning of hand injuries

When replacing the sanding or polishing disc, wear suitable protective gloves.



Info

Changing the sanding or polishing disc requires a size T-10 Torx screwdriver as well as a wrench with a width across flats of 17 mm (SW17). The tools required for the change is not included in the scope of delivery.

To change the sanding disc, please proceed as follows:

- ✓ The device is switched off and the mains plug is disconnected.
- 1. Loosen the screws (47) of the lateral protective cover (48). To do so, use a size T-10 Torx screwdriver.

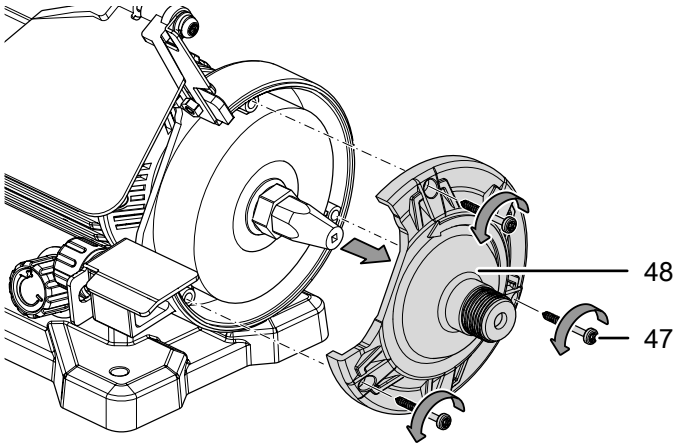

- 2. If necessary, unscrew the holding fixture of the flexible shaft (49) (only on the right side).
- 3. Hold the sanding disc (1) tight with one hand and loosen the union nut (50) with a SW 17 wrench.
- 4. Remove the spring washer (51).
- 5. Replace the worn sanding or polishing disc (1) by a new one.

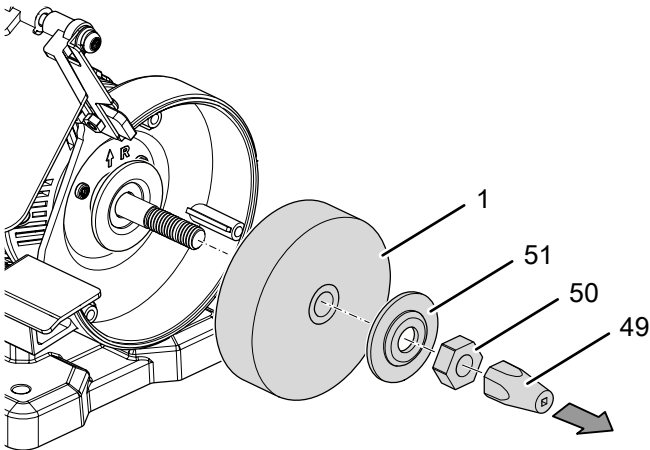

- 6. Put the spring washer (51) back onto the shaft.
- 7. Put the union nut (50) onto the shaft and screw the union nut (50) tight by holding the sanding or polishing disc in place.
- 8. If necessary, tighten the holding fixture of the flexible shaft (49) again.
- 9. Reattach the lateral protective cover (48).
- 10. Mount the screws (47) of the lateral protective cover (48). To do so, use a size T-10 Torx screwdriver.
- 11. Make sure that the tool is attached securely.

Readjusting the workpiece support

Note

Check the distance between the workpiece support and the sanding or polishing disc at regular intervals. The distance has to be as small as possible and should in no case be more than 2 mm.

Readjust the distance at regular intervals. If the distance required can no longer be set, the worn sanding or polishing disc must be replaced.

In order to readjust the distance of the workpiece support (33), please proceed as follows:

- 1. Loosen the knurled screw (32) on the workpiece support (33).
- 2. Adjust the workpiece support (33) so that the distance to the grinding or polishing wheel is less than 2 mm. In doing this, observe that the angle is always greater than 85°.

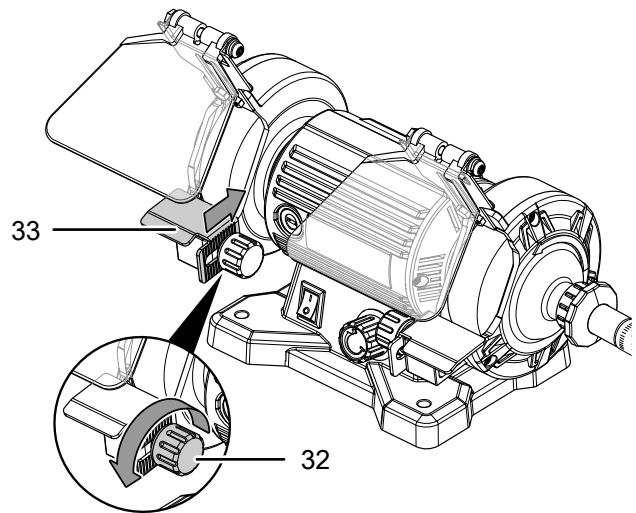

- 3. Retighten the knurled screw (32).

Cleaning

The device should be cleaned before and after each use.



Warning of electrical voltage

There is a risk of a short-circuit due to liquids penetrating the housing!
Do not immerse the device and the accessories in water. Make sure that no water or other liquids can enter the housing.

- Clean the device with a soft, damp and lint-free cloth. Make sure that no moisture enters the housing. Protect electrical components from moisture. Do not use any aggressive cleaning agents such as cleaning sprays, solvents, alcohol-based or abrasive cleaners to dampen the cloth.
- Dry the device with a soft, lint-free cloth.
- Remove any abrasive dust and, if applicable, wood chips from the tool holder.

Disposal

Always dispose of packing materials in an environmentally friendly manner and in accordance with the applicable local disposal regulations.



The icon with the crossed-out waste bin on waste electrical or electronic equipment stipulates that this equipment must not be disposed of with the household waste at the end of its life. You will find collection points for free return of waste electrical and electronic equipment in your vicinity. The addresses can be obtained from your municipality or local administration. You can also find out about other return options that apply for many EU countries on the website <https://hub.trotec.com/?id=45090>. Otherwise, please contact an official recycling centre for electronic and electrical equipment authorised for your country.

The separate collection of waste electrical and electronic equipment aims to enable the re-use, recycling and other forms of recovery of waste equipment as well as to prevent negative effects for the environment and human health caused by the disposal of hazardous substances potentially contained in the equipment.

Only for United Kingdom

According to Waste Electrical and Electronic Equipment Regulations 2013 (SI 2013/3113) (as amended) devices that are no longer usable must be collected separately and disposed of in an environmentally friendly manner.

Declaration of conformity

Declaration of conformity in accordance with the EC Machinery Directive 2006/42/EC, Annex II, Part 1, Section A

We – Trotec GmbH – declare in sole responsibility that the product designated below was developed, constructed and produced in compliance with the requirements of the EC Machinery Directive in the version 2006/42/EC.

Product model / Product: PBGS 10-120
Product type: bench grinding machine
Year of manufacture as of: 2022

Relevant EU directives:

- 2011/65/EU: 01/07/2011
- 2012/19/EU: 24/07/2012
- 2014/30/EU: 29/03/2014
- 2015/863/EU: 31/03/2015

Applied harmonised standards:

- EN ISO 12100:2010
- EN 55014-1:2017/A11:2020
- EN 62841-1:2015
- EN 62841-3-4:2016/A12:2020

Applied national standards and technical specifications:

- EN 55014-2:2015
- EN IEC 61000-3-2:2019
- EN 61000-3-3:2013/A1:2019

Manufacturer and name of the authorised representative of the technical documentation:

Trotec GmbH
Grebbeener Straße 7, D-52525 Heinsberg
Phone: +49 2452 962-400
E-mail: info@trotec.de

Place and date of issue:
Heinsberg, 31.05.2022



Detlef von der Lieck, Managing Director

Trotec GmbH

Grebbener Str. 7
D-52525 Heinsberg

☎ +49 2452 962-400

☎ +49 2452 962-200

✉ info@trotec.com

www.trotec.com