

EN

ORIGINAL INSTRUCTIONS
3-IN-1 MULTI-FUNCTIONAL
SANDER



Table of contents

Information on the use of these instructions 2

Safety 3

Information about the device..... 7

Transport and storage..... 9

Start-up..... 9

Operation 14

Errors and faults..... 16

Maintenance 17

Disposal 18

Declaration of conformity 18

Information on the use of these instructions

Symbols

 **Warning of electrical voltage**
This symbol indicates dangers to the life and health of persons due to electrical voltage.

 **Warning of explosive substances**
This symbol indicates dangers to the life and health of persons due to potentially explosive substances.

 **Warning of hot surface**
This symbol indicates dangers to the life and health of persons due to hot surface.

 **Warning**
This signal word indicates a hazard with an average risk level which, if not avoided, can result in serious injury or death.

 **Caution**
This signal word indicates a hazard with a low risk level which, if not avoided, can result in minor or moderate injury.

Notice
This signal word indicates important information (e.g. material damage), but does not indicate hazards.

 **Info**
Information marked with this symbol helps you to carry out your tasks quickly and safely.

 **Follow the manual**
Information marked with this symbol indicates that the instructions must be observed.

 **Wear hearing protection**
Information marked with this symbol indicates that you should wear hearing protection.

 **Wear safety glasses**
Information marked with this symbol indicates that you should wear eye protection.

 **Wear a protective mask**
Information marked with this symbol indicates that you should wear a protective mask.

 **Wear protective clothing**
Information marked with this symbol indicates that you should wear protective clothing.

 **Wear protective gloves**
Information marked with this symbol indicates that you should wear protective gloves.

You can download the current version of these instructions via the following link:



PMSS 11-220



<https://hub.trotec.com/?id=45234>

Safety

General Power Tool Safety Warnings



Warning

Read all safety warnings, instructions, illustrations and specifications provided with this power tool.

Failure to follow all instructions listed below may result in electric shock, fire and/or serious injury.

Save all warnings and instructions for future reference.

The term *power tool* in the warnings refers to your mains-operated (corded) power tool or battery-operated (cordless) power tool.



General Power Tool Safety Warnings – Work area safety

- **Keep work area clean and well lit.** Clutter or dark areas invite accidents.
- **Do not operate power tools in explosive atmosphere, such as in the presence of flammable liquids, gases or dust.** Power tools create sparks which may ignite the dust or fumes.
- **Keep children and bystanders away while operating a power tool.** Distractions can cause you to lose control.



General Power Tool Safety Warnings – Electrical safety

- **Power tool plugs must match the outlet. Never modify the plug in any way. Do not use any adapter plugs with earthed (grounded) power tools.** Unmodified plugs and matching outlets will reduce risk of electric shock.
- **Avoid body contact with earthed or grounded surfaces, such as pipes, radiators, ranges and refrigerators.** There is an increased risk of electric shock if your body is earthed or grounded.
- **Do not expose power tools to rain or wet conditions.** Water entering a power tool will increase the risk of electric shock.
- **Do not abuse the cord. Never use the cord for carrying, pulling or unplugging the power tool. Keep cord away from heat, oil, sharp edges or moving parts.** Damaged or entangled cords increase the risk of electric shock.
- **When operating a power tool outdoors, use an extension cord suitable for outdoor use.** Use of a cord suitable for outdoor use reduces the risk of electric shock.
- **If operating a power tool in a damp location is unavoidable, use a residual current device (RCD) protected supply.** Use of an RCD reduces the risk of electric shock.





General Power Tool Safety Warnings – Personal safety

- **Stay alert, watch what you are doing and use common sense when operating a power tool. Do not use a power tool while you are tired or under the influence of drugs, alcohol or medication.** A moment of inattention while operating power tools may result in serious personal injury.
- **Use personal protective equipment. Always wear eye protection.** Protective equipment such as a dust mask, non-skid safety shoes, hard hat or hearing protection used for appropriate conditions will reduce personal injuries.
- **Prevent unintentional starting. Ensure the switch is in the off-position before connecting to power source and/or battery pack, picking up or carrying the tool.** Carrying power tools with your finger on the switch or energising power tools that have the switch on invites accidents.
- **Remove any adjusting key or wrench before turning the power tool on.** A wrench or a key left attached to a rotating part of the power tool may result in personal injury.
- **Do not overreach. Keep proper footing and balance at all times.** This enables better control of the power tool in unexpected situations.
- **Dress properly. Do not wear loose clothing or jewellery. Keep your hair and clothing away from moving parts.** Loose clothes, jewellery or long hair can be caught in moving parts.
- **If devices are provided for the connection of dust extraction and collection facilities, ensure these are connected and properly used.** Use of dust collection can reduce dust-related hazards.
- **Do not let familiarity gained from frequent use of tools allow you to become complacent and ignore tool safety principles.** A careless action can cause severe injury within a fraction of a second.



General Power Tool Safety Warnings – Power tool use and care

- **Do not force the power tool. Use the correct power tool for your application.** The correct power tool will do the job better and safer at the rate for which it was designed.
- **Do not use the power tool if the switch does not turn it on and off.** Any power tool that cannot be controlled with the switch is dangerous and must be repaired.

- **Disconnect the plug from the power source and/or remove the battery pack, if detachable, from the power tool before making any adjustments, changing accessories, or storing power tools.** Such preventive safety measures reduce the risk of starting the power tool accidentally.
 - **Store idle power tools out of the reach of children and do not allow persons unfamiliar with the power tool or these instructions to operate the power tool.** Power tools are dangerous in the hands of untrained users.
 - **Maintain power tools and accessories. Check for misalignment or binding of moving parts, breakage of parts and any other condition that may affect the power tool's operation. If damaged, have the power tool repaired before use.** Many accidents are caused by poorly maintained power tools.
 - **Keep cutting tools sharp and clean.** Properly maintained cutting tools with sharp cutting edges are less likely to bind and are easier to control.
 - **Use the power tool, accessories and tool bits etc. in accordance with these instructions, Take into account the working conditions and the work to be performed.** Use of the power tool for operations different from those intended could result in a hazardous situation.
 - **Keep handles and grasping surfaces dry, clean and free from oil and grease.** Slippery handles and grasping surfaces do not allow for safe handling and control of the tool in unexpected situations.
-  **General Power Tool Safety Warnings – Service**
- **Have your power tool serviced by a qualified repair person using only identical replacement parts.** This will ensure that the safety of the power tool is maintained.
-  **Safety Warnings for Sanding Operations**
- Read all safety warnings, instructions, illustrations and specifications provided with this power tool. Failure to follow all instructions listed below may result in electric shock, fire and / or serious injury.
 - **Do not use accessories which are not specifically designed and recommended by the tool manufacturer.** Just because the accessory can be attached to your power tool, it does not assure safe operation.
 - **Do not use a damaged accessory. Before each use inspect the accessory. If power tool or accessory is dropped, inspect for damage or install an undamaged accessory. After inspecting and installing an accessory, position yourself and bystanders away from the plane of the rotating accessory and run the power tool at maximum no-load speed for one minute.** Damaged accessories will normally break apart during this test time.
 - **Wear personal protective equipment. Depending on application, use face shield, safety goggles or safety glasses. As appropriate, wear dust mask, hearing protectors, gloves and workshop apron capable of stopping small abrasive or workpiece fragments.** The eye protection must be capable of stopping flying debris generated by various operations. The dust mask or respirator must be capable of filtrating particles generated by your operation. Prolonged exposure to high intensity noise may cause hearing loss.
 - **Keep bystanders a safe distance away from work area. Anyone entering the work area must wear personal protective equipment.** Fragments of workpiece or of a broken accessory may fly away and cause injury beyond immediate area of operation.
 - **Never lay the power tool down until the accessory has come to a complete stop.** The spinning accessory may grab the surface and pull the power tool out of your control.
 - **Do not run the power tool while carrying it at your side.** Accidental contact with the spinning accessory could snag your clothing, pulling the accessory into your body.
 - **Regularly clean the power tool's air vents.** The motor's fan will draw the dust inside the housing and excessive accumulation of powdered metal may cause electrical hazards.
 - **Do not operate the power tool near flammable materials.** Sparks could ignite these materials.
 - **Only use the power tool for dry sanding.** Water entering an electrical appliance increases the risk of electric shock.
 - **Secure the workpiece.** The grip of tensioning devices or a vice is more secure than holding the workpiece only by hand.
 - **During operation hold onto the power tool with both hands.** Make sure that you stand firmly on the ground. It is safer to handle the power tool with two hands.
 - **For processing wood, or in particular materials that produce harmful dusts when sanded, connect the power tool to an appropriate external exhaust system.**

- **Only hold the power tool against the workpiece when the tool is switched on and running. If you are finished with processing the workpiece, lift the power tool off the workpiece before you switch it off.**
- **Make sure that nobody's safety is jeopardized by flying sparks. Remove combustible materials from the working environment.** Grinding metal causes sparks to fly.
- **Always keep the connection cable behind the device and out of its operating range.**
- **If the connection cable needs to be replaced, this must be done by the manufacturer or his agent in order to avoid safety hazards.**
- **Using a power tool that comes equipped with a dust collector or can be connected to the vacuum cleaner by means of a dust extraction device involves a fire hazard.** In unfavourable conditions – e.g. in case of flying sparks caused by grinding metal or metal remainders in wood – the wood dust inside the dust collector (or in the vacuum cleaner's dust collection bag) might self-ignite. The risk is particularly high when the wood dust is mixed with paint residues or other chemical substances and the sanding material is hot after a longer period of work. Therefore, avoid overheating of the workpiece and of the power tool at all times and empty the dust collector or the vacuum cleaner's dust bag before taking work breaks.
- **Do not use the dust extraction system when grinding metals.**
- **Ensure sufficient ventilation.**
- **Hold the power tool by the insulated gripping surfaces, as the grinding surface could hit the connecting cable.** Damaging a live wire might energize metal parts of the power tool and lead to an electric shock.
- **Do not use excessively oversized sanding disc paper. Follow manufacturers recommendations, when selecting sanding paper.** Larger sanding paper extending beyond the sanding pad presents a laceration hazard and may cause snagging, tearing of the disc or kickback.

Intended use

Only use the device PMSS 11-220 for the dry grinding of wood, plastics, metal and painted surfaces whilst adhering to the technical data.

The device must only be used for dry sanding.

We recommend using the power tool with original Trotec accessories.

Any use other than the intended use is regarded as misuse.

Reasonably foreseeable misuse

The device is not intended for processing damp materials.

Personnel qualification

People who use this device must:

- have read and understood the instructions, especially the Safety chapter.

Personal protective equipment



Wear hearing protection.

Excessive noise can lead to hearing loss.



Wear eye protection.

With it you protect your eyes from splintering, falling and flying pieces which could cause injuries.



Wear a protective mask.

It saves you from inhaling harmful dusts generated when processing workpieces.



Wear protective gloves.

They protect your hands from burns, crushing injuries and skin abrasions.



Wear tight-fitting protective clothing.

This protects you from the draw-in and entanglement hazard posed by rotating parts.

Residual risks



Warning of electrical voltage

Electric shock due to insufficient insulation!

Check the device for damages and proper functioning before each use.

If you detect damages, do not use the device any longer.

Do not use the device when either the device or your hands are damp or wet!



Warning of electrical voltage

Work on the electrical components must only be carried out by an authorised specialist company!



Warning of electrical voltage

Before any work on the device, remove the mains plug from the mains socket!

Do not touch the mains plug with wet or damp hands. Hold onto the mains plug while pulling the power cable out of the mains socket.



Warning of electrical voltage

There is a risk of a short-circuit due to liquids penetrating the housing!

Do not immerse the device and the accessories in water. Make sure that no water or other liquids can enter the housing.

**Warning of explosive substances**

Fine dust produced during grinding is highly flammable. Risk of fire and explosion!
Use the dust collector or a dust extraction system for collecting the produced dusts.
Empty the dust collector before taking work breaks.

**Warning of explosive substances**

Wood dust inside the dust collector can self-ignite in case of flying sparks. Do not use the dust extraction system when grinding metals!
Wood dust can intermix with varnish residues or other chemical substances.
Risk of fire and explosion!
Avoid overheating of the workpiece and the device.
Empty the dust collector or the vacuum cleaner's dust collection bag at regular intervals.

**Warning of hot surface**

The insertion tool might still be hot after the application. Burn hazard when touching the insertion tool.
Do not touch the insertion tool bare-handed!
Wear protective gloves!

**Warning of hot surface**

The workpiece becomes hot during grinding. Risk of burns.
Do not touch the processed part of the workpiece!
Allow it to cool down.
Wear protective gloves!

**Warning**

Toxic dusts!
The harmful / toxic dusts produced during operation pose of risk to the health of the operator and persons in the vicinity.
Wear eye protection and a dust mask!

**Warning**

Do not process materials containing asbestos.
Asbestos is considered carcinogenic.

**Warning**

Risk of injuries caused by flying parts.
Use a dust or chip bag or a dust extraction system.

**Warning**

Dangers can occur at the device when it is used by untrained people in an unprofessional or improper way!
Observe the personnel qualifications!

**Warning**

The device is not a toy and does not belong in the hands of children.

**Warning**

Risk of suffocation!
Do not leave the packaging lying around. Children may use it as a dangerous toy.

**Caution**

Vibration emissions can cause a health hazard if the device is used for an extended period of time or if it is not properly handled and maintained.

**Caution**

Keep a sufficient distance from heat sources.

Notice

If you store or transport the device improperly, the device may be damaged.
Note the information regarding transport and storage of the device.

Behaviour in the event of an emergency / emergency stop function

Emergency stop:

Removing the mains plug from the mains socket results in the function of the device immediately stopping. In order to secure the device against accidental switch-on, leave the mains plug disconnected.

Behaviour in the event of an emergency:

1. Switch the device off.
2. In an emergency, disconnect the device from the mains feed-in: Hold onto the mains plug while pulling the power cable out of the mains socket.
3. Do not reconnect a defective device to the mains.

Information about the device

Device description

The device PMSS 11-220 is a 3-in-1 multi-functional sander for dry sanding.

The device is equipped with a 200 W motor.

The three sanding plates delta sander, random orbital sander and orbital sander are suitable for sanding wooden surfaces, plastic, metal, spackle and paints in corners, along edges and on larger surfaces.

For material-compatible working, the nominal oscillation rate can be set for 6 steps within a range of 14,000 to 24,000 opm at the setting wheel.

The device is fitted with an on / off switch for continuous operation enabling convenient and fatigue-free working.

The tool-free clamping system/Velcro® system permits a simple exchange of sanding sheets.

A clean working environment can be accomplished by use of the dust collector with integrated filter and the reducer for external dust extraction.

Device depiction

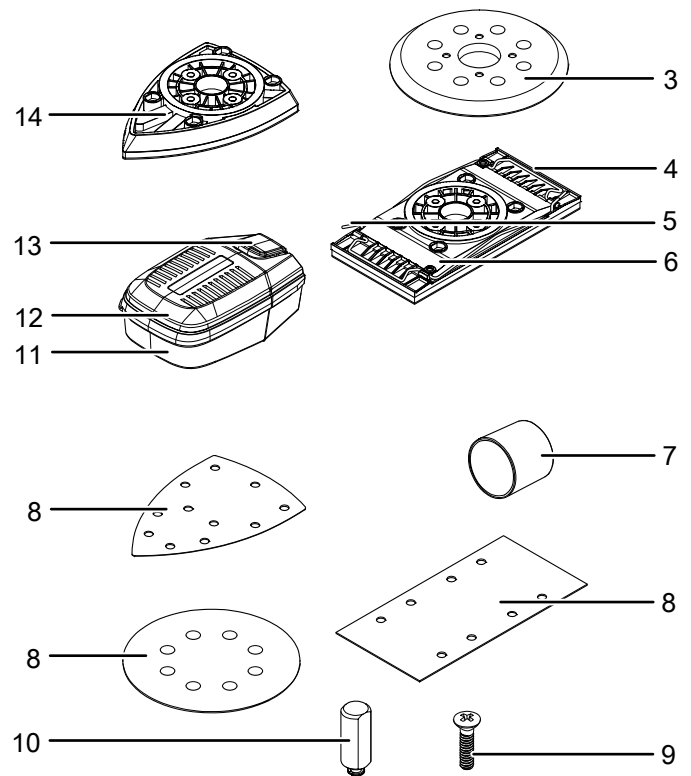
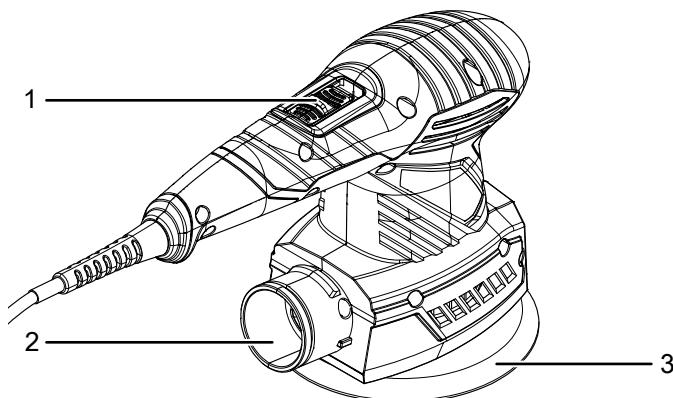
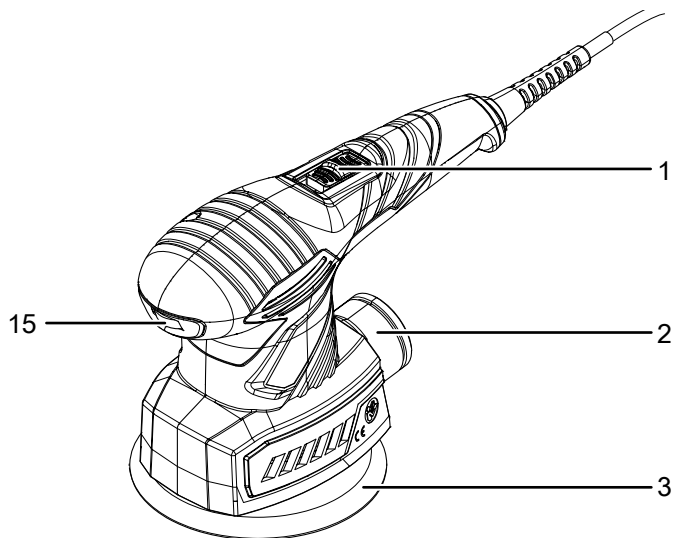

| No. | Designation |
|-----|--|
| 1 | On/off switch |
| 2 | Dust extraction connection |
| 3 | Random orbital sanding plate |
| 4 | Clamping bracket |
| 5 | Locking lever |
| 6 | Orbital sanding plate |
| 7 | Reducer |
| 8 | Sanding sheet |
| 9 | Screw |
| 10 | Rubber pin |
| 11 | Dust collector with filter |
| 12 | Tab |
| 13 | Dust box release button |
| 14 | Delta sanding plate |
| 15 | Setting wheel for oscillation rate selection |

Scope of delivery

- 1 x Device PMSS 11-220
- 1 x Dust collector
- 1 x Reducer
- 1 x Orbital sanding plate
- 1 x Random orbital sanding plate
- 1 x Delta sanding plate
- 3 x Sanding sheet for wood, grain size: 80 for random orbital sanding plate, orbital sanding plate, delta sanding plate
- 3 x Sanding sheet for wood, grain size: 240 for random orbital sanding plate, orbital sanding plate, delta sanding plate
- 8 x Rubber pin (4 x preassembled)
- 8 x Screw (4 x preassembled)
- 1 x Transport case
- 1 x Manual

Technical data

| Parameter | Value |
|--|--|
| Model | PMSS 11-220 |
| Mains connection | 230 V / 50 Hz |
| Power consumption | 200 W |
| Nominal oscillation rate | 14,000 – 24,000 opm |
| Idle speed | 7,000 – 12,000 rpm |
| Orbit diameter | 2 mm |
| Grinding surface | |
| Delta sanding plate | 108 cm ² |
| Random orbital sanding plate | 116 cm ² |
| Orbital sanding plate | 165 cm ² |
| Cable length | 3 m |
| Protection class | II (double insulation) /  |
| Weight | 1.5 kg |
| Vibration information according to EN 62841 | |
| Vibration emission value main handle a _h | 10.9 m/s ² |
| Vibration emission value front handle a _h | 13.7 m/s ² |
| Uncertainty K | 1.5 m/s ² |
| Sound values according to EN 62841 | |
| Sound pressure level L _{pA} | 79 dB(A) |
| Sound power L _{WA} | 90 dB(A) |
| Uncertainty K | 3 dB |

Information on noise and vibration:

- The specified total vibration **and noise emission values** were measured by means of a test procedure standardized in EN 62841 and can be consulted for the comparison of one power tool with another.
- The specified total vibration **and noise emission values** can also be used for preliminary load assessment.



Caution

Vibration emissions can cause a health hazard if the device is used for an extended period of time or if it is not properly handled and maintained.

- The actual vibration **and noise emission** may differ from the stated values during operation of the power tool. This depends on how the power tool is used and especially on the type of workpiece being processed. Try to keep the vibration load to a minimum. Exemplary measures for reducing the vibration load include wearing gloves during operation of the tool and the limitation of working hours. All parts of an operating cycle must be considered for this (e.g. times at which the power tool is switched off and times when it is switched on but runs without load).



Wear hearing protection.

Excessive noise can lead to hearing loss.

Transport and storage

Notice

If you store or transport the device improperly, the device may be damaged.

Note the information regarding transport and storage of the device.

Transport

For transporting the device, use the transport case included in the scope of delivery in order to protect the device from external influences.

Before transporting the device, observe the following:

- Switch off the device.
- Hold onto the mains plug while pulling the power cable out of the mains socket.
- Allow the device to cool down.
- If attached, disconnect the dust extraction system from the device.

Storage

Before storing the device, proceed as follows:

- Switch off the device.
- Hold onto the mains plug while pulling the power cable out of the mains socket.
- Allow the device to cool down.
- If attached, disconnect the dust extraction system from the device.
- Clean the device as described in the Maintenance chapter.
- For storing the device, use the transport case included in the scope of delivery in order to protect the device from external influences.

When the device is not being used, observe the following storage conditions:

- dry and protected from frost and heat
- Ambient temperature below 45 °C
- Protected from dust and direct sunlight inside the transport case

Start-up

Unpacking the device

- Take the transport case out of the packaging.



Warning of electrical voltage

Electric shock due to insufficient insulation!

Check the device for damages and proper functioning before each use.

If you detect damages, do not use the device any longer.

Do not use the device when either the device or your hands are damp or wet!

- Check the contents of the transport case for completeness and look for damages.



Warning

Risk of suffocation!

Do not leave the packaging lying around. Children may use it as a dangerous toy.

- Dispose of the packaging material according to the national regulations.

Changing the sanding plate



Warning of electrical voltage

Before any work on the device, remove the mains plug from the mains socket!

Do not touch the mains plug with wet or damp hands. Hold onto the mains plug while pulling the power cable out of the mains socket.

Notice

The orbital sanding plate and the delta sanding plate can only be mounted in one direction.

When mounting the orbital sanding plate, the arrow must point to the front.

When mounting the delta sanding plate, the tip must point to the front.

Notice

The rubber pins may only be used for the orbital sanding plate and the delta sanding plate.

The random orbital sanding plate is preassembled.

You can change the sanding plate to carry out various activities.

✓ Use tools suitable for the intended task.

1. Loosen the four screws (9) at the random orbital sanding plate (3).

⇒ The random orbital sanding plate is now loosened.

2. Remove the random orbital sanding plate (3) from the device.

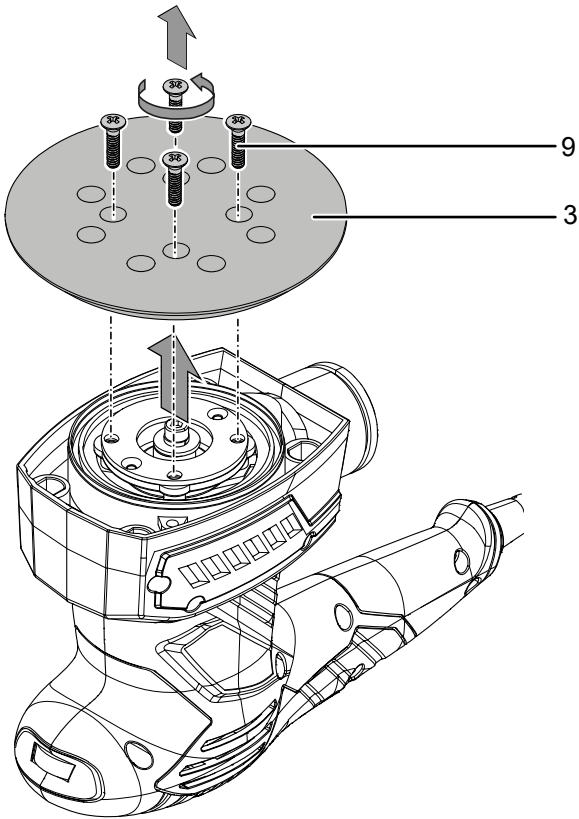

4. Check the felt ring (21) for correct fit.

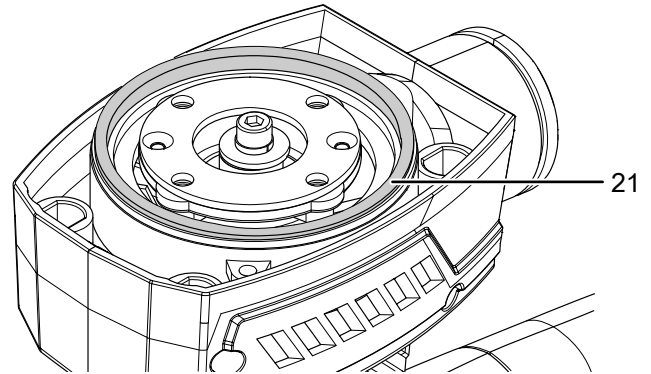

5. When mounting the orbital sanding plate (6) or the delta sanding plate (14), insert the four rubber pins (10) into the sanding plate so that the latching noses sit in the recesses (19).

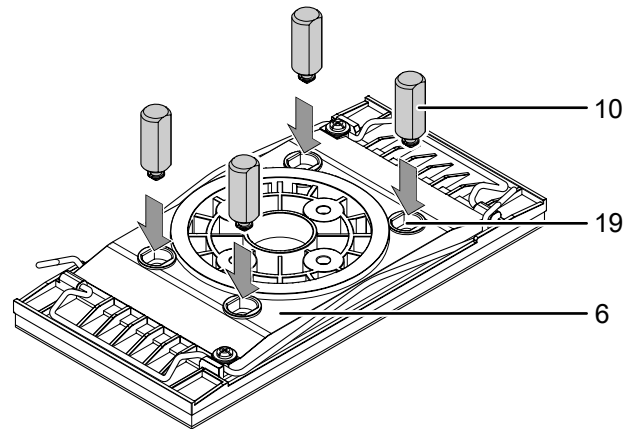

3. Adjust the flange (16) for the selected sanding plate. The threaded holes (17) for the screws must be aligned with the marks (18) on the device.

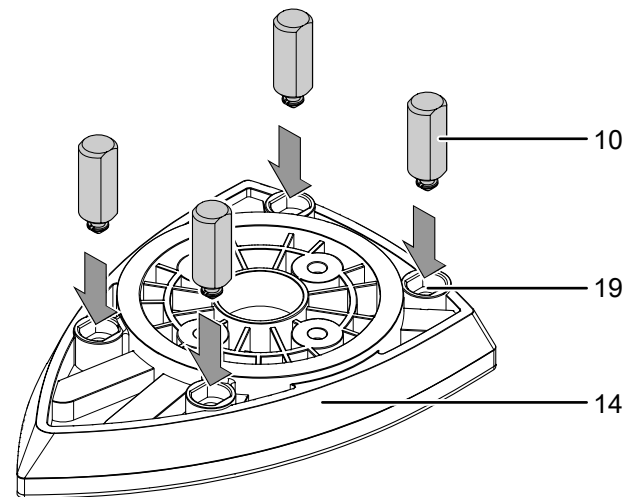
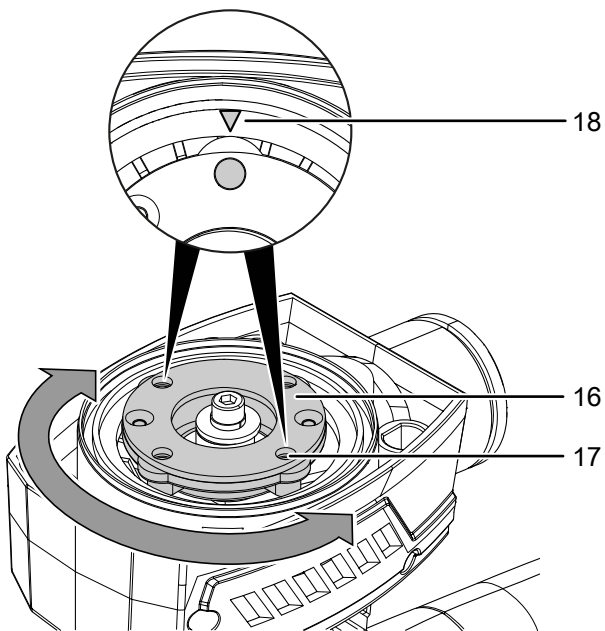

6. Place the orbital sanding plate (6) or delta sanding plate (14) onto the flange (16). When mounting the orbital sanding plate (6), the arrow (20) must point to the front. When mounting the delta sanding plate (14), the tip must point to the front.
7. Pay attention that the rubber pins (10) are positioned in the recesses (19) in the device. The rubber pins (10) ensure that the sanding plate is fixed in position.

8. Press the sanding plate onto the flange (16) until it clicks into place.
9. Tighten the four screws (9).

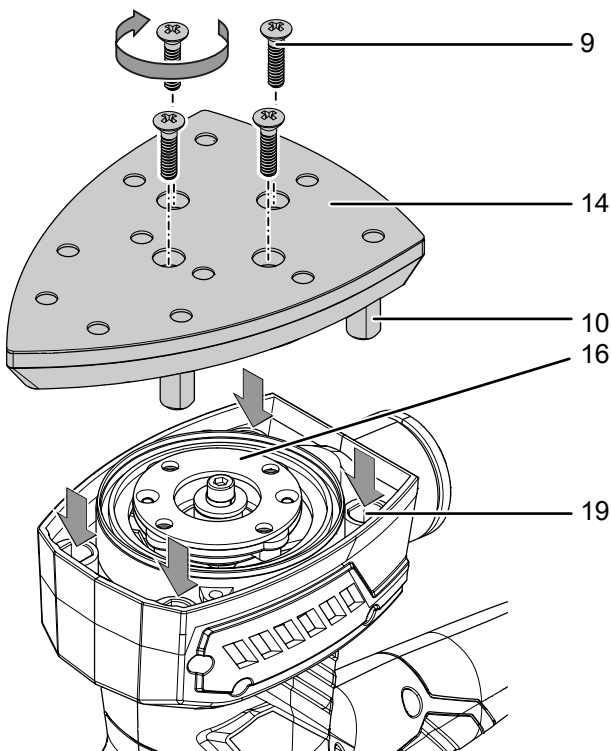
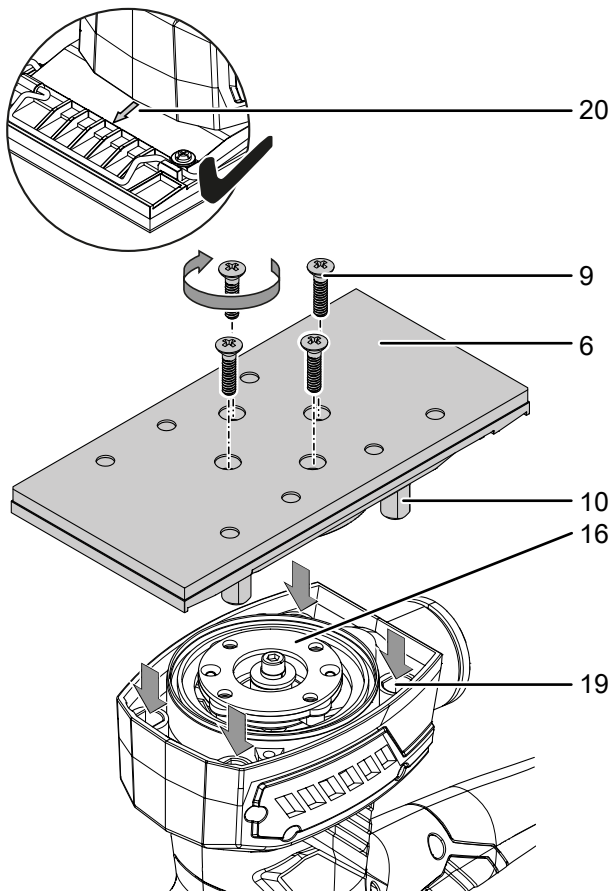

10. Check the sanding plate for tight fit.

Changing the sanding sheet



Warning of electrical voltage

Before any work on the device, remove the mains plug from the mains socket!
Do not touch the mains plug with wet or damp hands. Hold onto the mains plug while pulling the power cable out of the mains socket.

Notice

Make sure to exchange the sanding sheet in due time. Otherwise the sanding sheet might tear and cause damage to the workpiece.

Notice

The sanding sheet must not be kinked.

The sanding sheet can be exchanged for processing different materials. Moreover available are different grain sizes for coarse to fine sanding. It might be necessary to adjust the speed according to the new sanding sheet.

You can attach the sanding sheet to the sanding plate using the Velcro® backing.

Notice

Sanding accessories such as fleece and polishing felt are attached to the sanding plate in the same way.

1. If necessary, remove the sanding sheet that had already been attached to the sanding plate (3).
2. Before attaching a new sanding sheet, remove dust and dirt from the sanding plate e.g. using a brush. Tap off the dust from the sanding plate's Velcro® backing to ensure optimum adhesion.
3. Place the sanding sheet (8) with its smooth bottom side on the sanding plate (3) so that it fits exactly. The dust extraction holes of the sanding sheet (8) and sanding plate (3) should be aligned precisely.

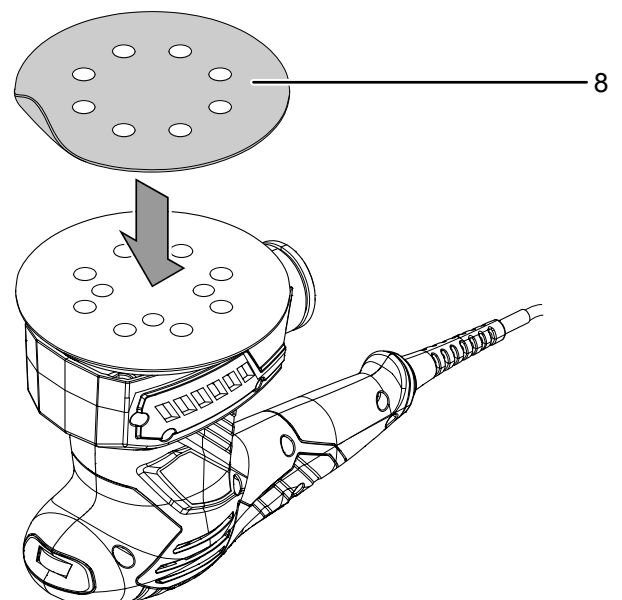

4. Firmly press the sanding sheet (8) down.
5. To exchange or remove the sanding sheet (8), simply pull it off the sanding plate (3).

When using the orbital sanding plate, you can also use sanding sheets **without Velcro® backing**.

Notice

When using unperforated sanding sheets, the dust extraction system cannot be used.

Notice

When cutting the sanding sheet to size, make sure that the sanding sheet is larger than the orbital sanding plate. Otherwise, you cannot fix the sanding sheet in the clamping bracket.

Please proceed as follows:

1. Fold down the locking lever (5) on one side of the device to open the corresponding clamping bracket (4).

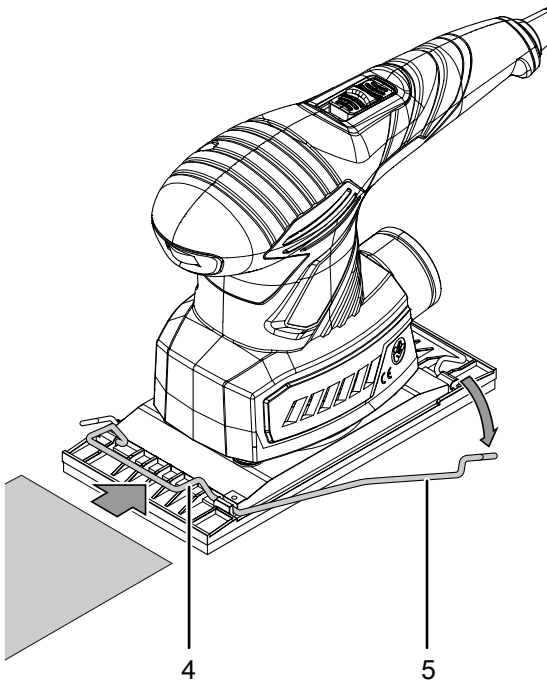

2. Slide the sanding sheet with its smooth bottom side under the open clamping bracket.

3. Fold the locking lever (5) back up to close the clamping bracket (4). Fix the locking lever at the orbital sanding plate again.
 - ⇒ The sanding sheet is now fixed on one side by the clamping bracket (4).

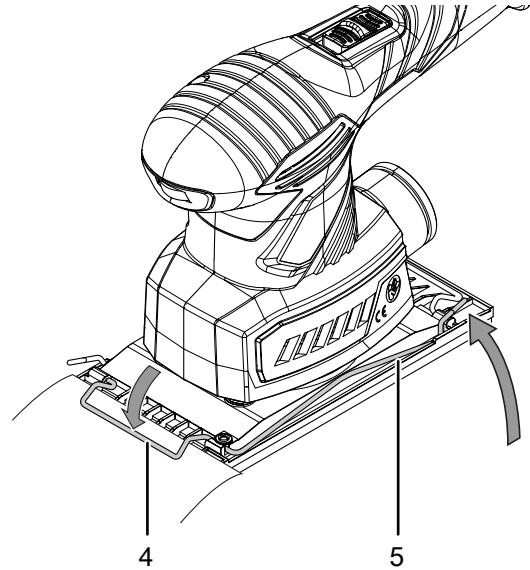

4. Guide the sanding sheet tightly along the orbital sanding plate to the other clamping bracket.

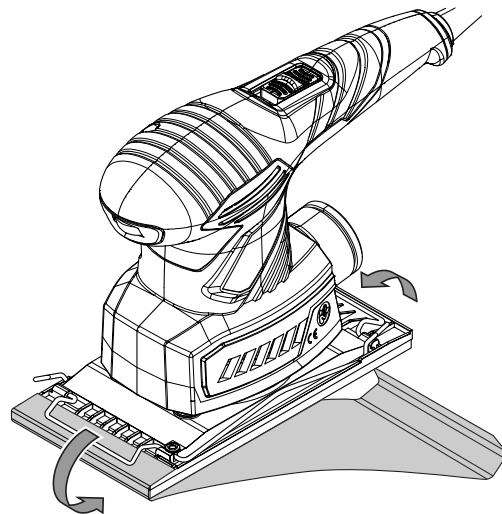

5. Repeat steps 1 to 3.

Assembling the dust collector



Warning of explosive substances

Wood dust inside the dust collector can self-ignite in case of flying sparks. Do not use the dust extraction system when grinding metals!

Wood dust can intermix with varnish residues or other chemical substances.

Risk of fire and explosion!

Avoid overheating of the workpiece and the device.

Empty the dust collector or the vacuum cleaner's dust collection bag at regular intervals.



Wear a protective mask

Wear an appropriate protective mask when working with the device.

Notice

The cover with the filter must point upwards.

Otherwise the dust collector cannot be installed.

1. Push the dust collector (11) onto the dust extraction connection (2). The two lugs (22) at the dust extraction connection (2) fit into the two grooves of the dust collector (11). The dust collector (11) must lock into place in the device.

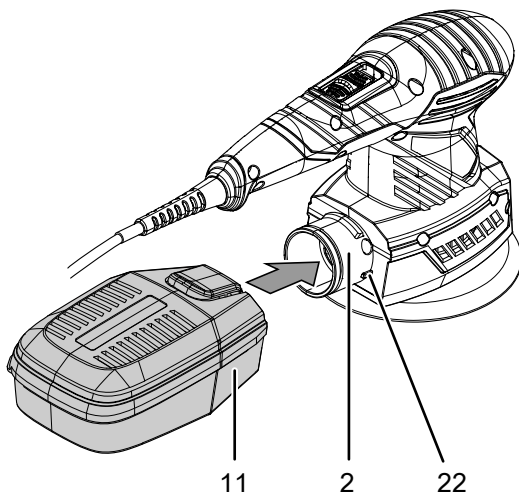

Mounting the external dust extraction system

Alternatively, you can also connect the dust extraction system to the device.



Warning of explosive substances

Wood dust inside the dust collector can self-ignite in case of flying sparks. Do not use the dust extraction system when grinding metals!

Wood dust can intermix with varnish residues or other chemical substances.

Risk of fire and explosion!

Avoid overheating of the workpiece and the device.

Empty the dust collector or the vacuum cleaner's dust collection bag at regular intervals.



Caution

Use a special vacuum cleaner to suck off harmful or toxic materials.

1. Insert the reducer (7) for the external dust extraction system into the dust extraction connection (2).
2. Connect a suitable vacuum cleaner (e.g. industrial vacuum cleaner) to the reducer (7). If anything is unclear or if you have questions, please contact the manufacturer of your vacuum cleaner.

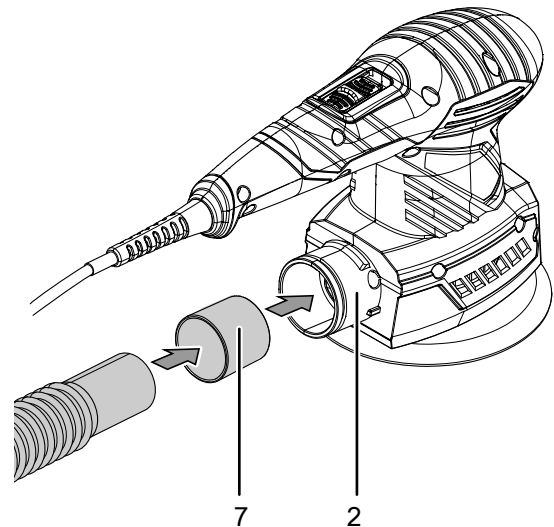

Oscillation rate selection

By use of the setting wheel for oscillation rate selection you can change the oscillation rate at any time, even during operation of the device. The required oscillation rate depends on the material and the operating conditions and can be determined by way of field-testing. For sanding harder materials such as wood or metal we recommend a higher oscillation rate, for softer materials e.g. non-ferrous metals and varnishes a low oscillation rate is sufficient.

The setting range covers the levels 1 – 6 (14,000 – 24,000 rpm).

1. Turn the setting wheel (15) to the desired oscillation rate.

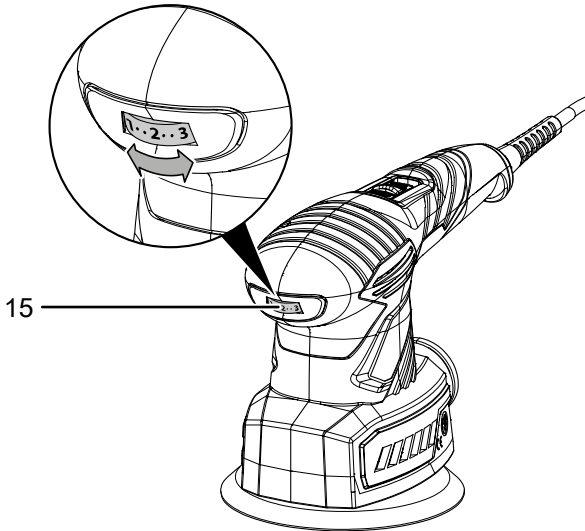

Connecting the power cable

1. Insert the mains plug into a properly secured mains socket.

Operation

Tips and notes on handling the 3-in-1 multi-functional sander

General information:

- Only use sanding sheets which are approved for the device used.
- Check the sanding plate for correct fit before every application. The sanding plate must be firmly locked in place in the flange.
- Before every application, make sure that you have selected the correct sanding sheet for the intended use. A coarse grit is suited for rough grinding, a fine grain size, on the other hand, is more appropriate for fine and finish grinding.
- Do not process wood and metal using the same sanding sheet.
- Only use intact, flawless sanding sheets. Damaged sanding sheets could tear and cause damage to the workpiece. Exchange sanding sheets in due time.
- Clamp the workpiece unless it is firmly and safely positioned by its own weight.
- Do not overload the device so that it comes to a standstill.
- Keep the venting slots clear to prevent the motor from overheating.

Sanding:

- The oscillation rate and grain size of the sanding sheet define the removal rate and the surface finish.
- Always sand in parallel to the grinding path ensuring an appropriate overlap.
- Do not apply excessive contact pressure. Increased contact pressure leads to a greater wear of the device and the sanding sheet.
- If the material's surface is untreated, start grinding with coarse or medium grain size and finish off with a fine grit.
- Best use a coarse grain size (40 or 60 grit) for removing paint and for rough grinding particularly raw wood. For surface-grinding undressed or sawn timber use abrasive belts of medium grit (grain size 80, 100 or 120). Use a fine grit (grain size 180, 240 or 320) to smoothen and fine-grind timber and surfaces coated with old paint as well as for dry sanding untreated wooden surfaces.
- Avoid the accumulation of dust at the workplace, always use a dust extraction system when grinding.
- Use the front or lateral edge of the sanding sheet on the sanding plate to process poorly accessible spots.
- Use a dust extraction system when grinding off residual paint. Paint residues might smelt and then smudge both workpiece and sanding sheet.

- Switch the device on before applying it to the workpiece. Once the grinding process is concluded, lift the device off the workpiece before you switch it off.

The non-binding values listed in the table below shall serve as a point of reference for selecting the right sanding sheet for the task at hand:

| | | |
|--|--------------------|-----------------|
| For processing paint and lacquer layers or primers such as filler and spackle | Grain size: | 40 – 240 |
| For grinding off paint | coarse | 40, 60 |
| For sanding primer paint | medium | 80, 120 |
| For final sanding of primers before lacquering | fine | 180, 240 |
| For processing any wood-based material | grain size: | 40 – 240 |
| For pre-grinding e.g. of rough, unplaned beams and boards | coarse | 40, 60 |
| For surface grinding and levelling of small irregularities | medium | 80, 100, 120 |
| For fine and finish grinding of hard wood | fine | 180, 240 |

Switching the device on and off

Wear your personal protective equipment when working with the device.



Warning



The event of a temporary power failure can lead to the device accidentally switching on.

Even if there is no voltage present, always switch the device off using the on/off switch.

Hold onto the mains plug while pulling the power cable out of the mains socket.

1. Slide the on/off switch (1) to I.

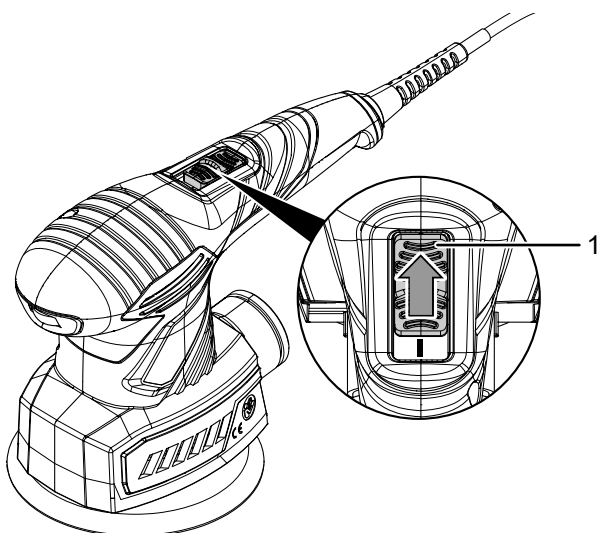

3. Lift the device off the workpiece before you switch it off.
4. To switch the device off, slide the on/off switch (1) to 0.

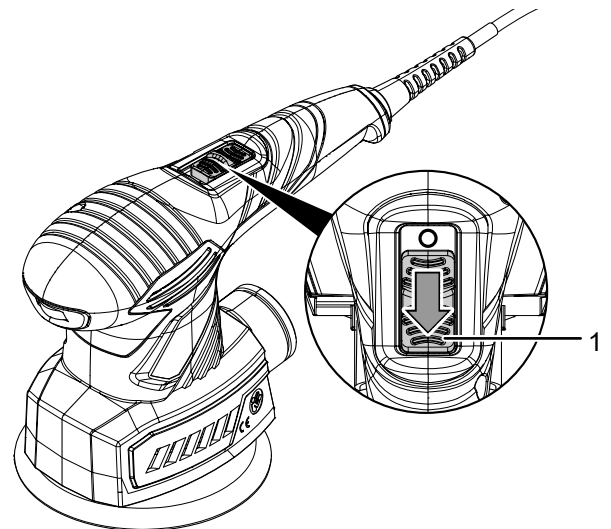

Shutdown



Warning of electrical voltage

Do not touch the mains plug with wet or damp hands.

- Switch off the device.
- Hold onto the mains plug while pulling the power cable out of the mains socket.
- If required, allow the device to cool down.
- Remove the tool from the device (see Start-up chapter).
- If attached, disconnect the dust extraction system from the device.
- Clean the device according to the Maintenance chapter.
- Store the device according to the Transport and storage chapter.

2. Position the device on the workpiece.

Errors and faults

The device has been checked for proper functioning several times during production. If malfunctions occur nonetheless, check the device according to the following list.

Troubleshooting tasks which require the housing to be opened must only be carried out by an authorized specialist electrical company or by Trotec.

Notice

Wait for at least 3 minutes after maintenance and repair work. Only then switch the device back on.

Light smoke or odour is emitted during the first use:

- This is not a fault. These phenomena disappear after a brief runtime.

The device does not start:

- Check the power connection.
- Check the power cable and mains plug for damage. If you notice damages, do not try to take the device back into operation.

If the supply cord is damaged, it must be replaced by the manufacturer, its service agent or similarly qualified persons in order to avoid a hazard.

- Check the on-site fusing.

The sanding plate does not move although the motor is running:

- Make sure that there is no workpiece debris blocking the drive. Remove the blockages, if any.
- Check whether you have mounted a sanding plate that is suitable for this device.

The sanding plate is loose:

- Check whether you have mounted a sanding plate that is suitable for this device.
- Check the sanding plate for tight fit. If necessary, tighten the screws.
- If necessary, check the rubber pins in the sanding plate for correct fit.

The motor slows down:

- Check whether the device is overloaded by the workpiece.
- Reduce the pressure applied on the workpiece.
- Check whether the workpiece is suitable for the tasks to be carried out.

The surface of the workpiece is not smooth or the grinding performance is insufficient:

- Check whether the selected sanding sheet is suitable for the material to be processed.
- If the sanding sheet is worn, replace it with a new one, see chapter Changing the sanding sheet.
- Check the oscillation rate setting. It must be suitable for both the sanding sheet and the material.
- Select a higher oscillation rate by turning the setting wheel for the oscillation rate selection to the desired level.

The sanding sheet wears off quickly:

- Check whether the selected sanding sheet is suitable for the material to be processed.
- Reduce the pressure applied on the workpiece.
- Select a lower oscillation rate by turning the setting wheel for the oscillation rate selection to the desired level.

The device becomes hot:

- Make sure not to exert too much pressure on the device during operation.
- Select a lower oscillation rate by turning the setting wheel for the oscillation rate selection to the desired level.
- Check whether the selected sanding sheet is suitable for the tasks to be carried out.
- Keep the venting slots clear to prevent the motor from overheating.

The device still does not operate correctly after these checks:

Please contact the customer service. If necessary, bring the device to an authorised specialist electrical company or to Trotec for repair.

Maintenance

Activities required before starting maintenance



Warning of electrical voltage

Do not touch the mains plug with wet or damp hands.

- Switch off the device.
- Hold onto the mains plug while pulling the power cable out of the mains socket.
- Allow the device to cool down completely.



Warning of electrical voltage

Maintenance tasks which require the housing to be opened must only be carried out by authorised specialist companies or by Trotec.

Notes on maintenance

Cleaning

The device should be cleaned before and after each use.

Notice

The device does not have to be lubricated after cleaning.



Warning of electrical voltage

There is a risk of a short-circuit due to liquids penetrating the housing!

Do not immerse the device and the accessories in water. Make sure that no water or other liquids can enter the housing.

- Clean the device with a soft, damp and lint-free cloth. Make sure that no moisture enters the housing. Protect electrical components from moisture. Do not use any aggressive cleaning agents such as cleaning sprays, solvents, alcohol-based or abrasive cleaners to dampen the cloth.
- Dry the device with a soft, lint-free cloth.
- Keep the ventilation openings free from dust deposits to prevent overheating of the motor.
- Remove dust and chips from the chip ejector. If the chip ejector is blocked, clean it with suitable means (e.g. compressed air).

Emptying / cleaning the dust collector

The device accomplishes a high removal rate. For optimum working conditions regularly empty and clean the dust collector.

1. Detach the dust collector (11) from the dust extraction connection (2) by pressing the release button (13).

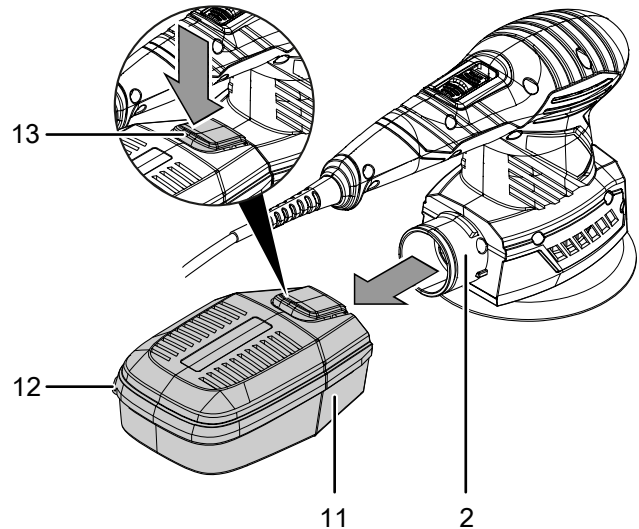

2. Open the dust collector (11) by pulling the tab (12).
3. Remove the cover from the dust collector.
4. Tap both parts of the dust collector against a solid surface to loosen the dust. Clean the filter.
5. Empty both parts completely. Use a brush to remove adherent abrasive dust.
6. Fit the cover back on the dust collector (11).
7. Push the dust collector (11) back onto the dust extraction connection (2). The two lugs (22) at the dust extraction connection (2) fit into the two grooves of the dust collector (11). The dust collector (11) must lock into place in the device.

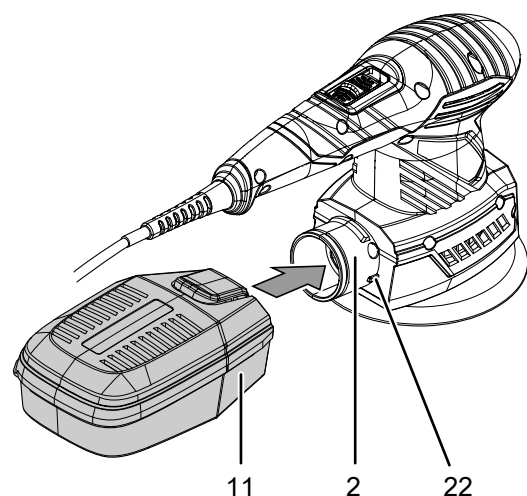

Cleaning / changing the filter insert of the dust collector

The filter insert has to be cleaned as soon as it is dirty. Check the filter insert for dirt once or twice a year.

The filter insert should be exchanged in case of heavy soiling or damage.

1. Remove the filter retainer with the filter insert from the dust collector cover.
2. Clean the filter insert with warm water mixed with a neutral cleaning agent.
3. Allow the filter insert to dry completely. Do not put a wet filter insert into the dust collector!
4. Fit the filter retainer with the filter insert back into the dust collector cover.

Disposal

Always dispose of packing materials in an environmentally friendly manner and in accordance with the applicable local disposal regulations.



The icon with the crossed-out waste bin on waste electrical or electronic equipment is taken from Directive 2012/19/EU. It states that this device must not be disposed of with the household waste at the end of its life. You will find collection points for free return of waste electrical and electronic equipment in your vicinity. The addresses can be obtained from your municipality or local administration. You can also find out about other return options that apply for many EU countries on the website <https://hub.trotec.com/?id=45090>. Otherwise, please contact an official recycling centre for electronic and electrical equipment authorised for your country.

The separate collection of waste electrical and electronic equipment aims to enable the re-use, recycling and other forms of recovery of waste equipment as well as to prevent negative effects for the environment and human health caused by the disposal of hazardous substances potentially contained in the equipment.

Only for United Kingdom

According to Waste Electrical and Electronic Equipment Regulations 2013 (SI 2013/3113) (as amended) devices that are no longer usable must be collected separately and disposed of in an environmentally friendly manner.

Declaration of conformity

Declaration of conformity in accordance with the EC Machinery Directive 2006/42/EC, Annex II, Part 1, Section A

We – Trotec GmbH – declare in sole responsibility that the product designated below was developed, constructed and produced in compliance with the requirements of the EC Machinery Directive in the version 2006/42/EC.

Product model / Product: PMSS 11-220

Product type: 3-in-1 multi-functional sander

Year of manufacture as of: 2024

Relevant EU directives:

- 2011/65/EU
- 2014/30/EU

Applied harmonised standards:

- EN 62841-1:2015
- EN 62841-2-4:2014

Applied national standards and technical specifications:

- EN IEC 55014-1:2021
- EN IEC 55014-2:2021
- EN IEC 61000-3-2:2019/A1:2021
- EN 61000-3-3:2013/A2:2021

Manufacturer and name of the authorised representative of the technical documentation:

Trotec GmbH

Grebberer Straße 7, D-52525 Heinsberg

Phone: +49 2452 962-400

E-mail: info@trotec.de

Place and date of issue:

Heinsberg, 27.03.2024

Joachim Ludwig, Managing Director

Trotec GmbH

Grebener Str. 7
D-52525 Heinsberg

☎ +49 2452 962-400

☎ +49 2452 962-200

✉ info@trotec.com

www.trotec.com